

SERVICE MANUAL



**ARAGON
ARAGON GP
FORMULA R**

JR

ARAGON GP, ARAGON, FORMULA R

Service Manual

PREFACE

This workshop manual contains information about common service, repair, and maintenance works for all systems of the model CPI JR.

The manual is subdivided in chapters, in which the vehicle systems in question are explained. Every component or subsystem is treated in a section of its own. Some chapters contain a maintenance section with work processes which apply to several components or subsystems in the chapter.

Every section usually contains a description of the proceedings, installation, dismantling, assembly and examination of components. There are tables of special tools and specifications in chapters of their own. Where required, the use of the special tools is indicated in the individual chapter.

Every chapter starts with a chapter contents list, where all treated parts, work and checking operations are listed with detail of the page numbers.

The chapter page numbering is built up the following way:

Example: Fl 3 = group of Fl, page 3

The details contained in this manual and vehicle data correspond to the ones at the moment of printing. HANS LEEB Zweirad Handel GmbH reserves the right to end a model production any time and to change specifications and designs without a previous announcement and without obligations arising from it.

All rights reserved. This manual or extracts of it may not be reprinted, duplicated or translated without a written permission of HANS LEEB Zweirad Handel GmbH. Use of electronic and mechanical systems inclusively photocopiers, note equipment and systems for the data storage and data account is herein included.

TABLE OF CONTENTS

CHAPTERS	GROUP
GENERAL INFORMATION	GI
TECHNICAL DATA	TD
SPECIAL TOOLS	ST
CARBURETOR	FL
OIL PUMP	LB
CRANK DRIVE / CRANKCASE / CRANKSHAFT	CR
VARIOMATIC TRANSMISSION	VT
ELECTRICAL SYSTEM	ES

Copyright © 2008
HANS LEEB Zweirad Handel GmbH
Printed in Austria, March 2008

Pub. No.: WHB-JR-08

GENERAL INFORMATION

GENERAL INFORMATION	GI-2
WARNING AND SAFETY SYMBOLS	GI-3
VEHICLE IDENTIFICATION NUMBERS	GI-4
MAINTENANCE INSTRUCTIONS	GI-5

GENERAL INFORMATION

CAUTION

Suitable maintenance and repair proceedings are indispensable both for the safe and operationally reliable operation of a motor vehicle and for the personal safety of the mechanic.

Many proceedings, techniques, tooling and components are known for the various maintenance works that are required for a vehicle, and the knowledge of motor vehicle technicians differs likewise. Neither can this shop manual anticipate all eventualities arising from this fact, nor is it intended to point out all potential risks. Therefore, it is absolutely indispensable to make sure that neither personal safety nor the vehicle's roadworthiness is impaired when deviating from the instructions given here.

The following general warning instructions always have to be observed when maintaining the vehicle:



- Turn off the ignition, unless otherwise stipulated.
- Keep away from moving or rotating components when the engine is running.
- Avoid touching of hot components (exhaust manifold, exhaust pipe, catalytic converter, muffler) in order not to get burnt!
- If for maintenance works the engine must run, then pay attention to **sufficient ventilation** in closed rooms. Use suitable suctioning units to derive engine exhaust gases! Engine exhaust gases contain carbon monoxide, which can lead to unconsciousness and to death when in higher concentration.
- Batteries contain sulfuric acid (electrolyte). Avoid any contact with skin, eyes and mucous membranes, since that acid causes severe injuries! Operators have to wear suitable protective clothing and safety goggles according to the stipulations made by the respective professional organizations.
- In the case of contact with sulfuric acid, the concerned areas have to be cleaned with much water. In the case of contact with eyes, wash them with a lot of water and go to an ophthalmologist immediately!
- **Always keep sulfuric acid out of reach of children!**
- Fuel is extremely highly inflammable and the gasses are bad for health! During maintenance, closed rooms must always be sufficiently ventilated. Open flames, smoking or flying sparks are strictly to be avoided!
- Used oils, greases and other used lubricants are bad for health when at a longer / daily skin contact, and they can cause skin cancer. Avoid any unnecessary skin contact and clean wetted skin areas with water and soap after every contact.
- Brake fluid is extremely bad for health. The same safety instructions apply to works with brake fluid as in the case of sulfuric acid.
- Used acids, greases, oils, brake fluid as well as fuels are hazardous waste. They must be disposed separately and carefully and in accordance with the valid local regulations. This also applies to contaminated rags and components (e.g. oil filters).

CAUTION

The usage of low-quality fuels and lubricants, which do not correspond to the CPI specifications, can lead to severe engine and gear failures. Always use high-grade fuels and lubricants, which correspond to the specifications in the specifications chapter of this manual.

WARNING AND SAFETY SYMBOLS

The following symbols indicate that the vehicle technician must pay extra attention when performing maintenance works.

Symbol	Description	Symbol	Description
	It is indispensable to follow this instruction. Severe injuries or even the loss of life may result in the case of non-observance.		Component parts may get damaged when this instruction is not observed.
			This symbol provides useful information on how to perform proper repair or service work.

VEHICLE IDENTIFICATION NUMBERS



Oliver Sport / Formula R



Aragon / Aragon GP

The VEHICLE IDENTIFICATION NUMBER consists of 17 alphanumeric characters. In the case of versions 11 and 12 (Formula R), it is stamped on the center front steering tube behind the legshield. In the case of versions 7-10 (Aragon / Aragon GP), the VIN is stamped on the rear right-hand side of the frame. The cover must first be removed from there in order to make it visible. The engine number is stamped on the upper part of the left engine case of all vehicle versions.

R F T J R 4 5 A X 6 L 0 0 0 1 1 0

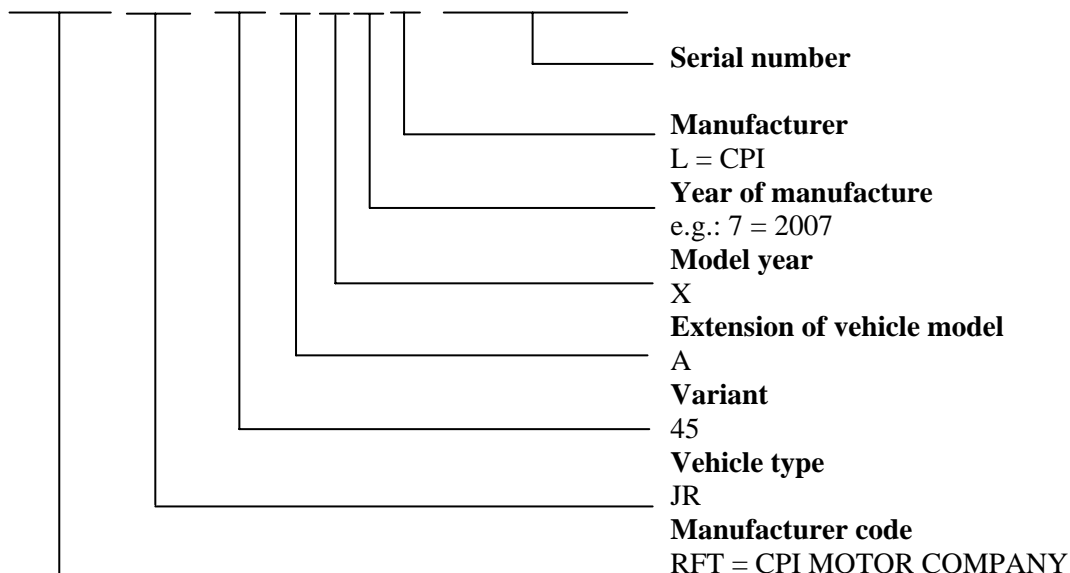

MAINTENANCE INSTRUCTIONS

PREPARING TOOLS AND MEASURING INSTRUMENTS

Before starting any maintenance works make sure that all necessary tools and measuring instruments are available.

SPECIAL TOOLS

Use special tools, if stipulated in the chapter.

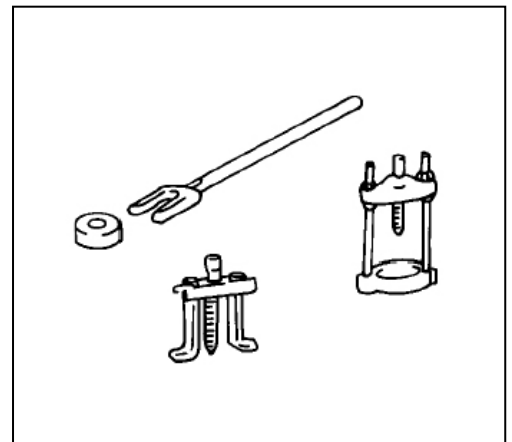

REMOVAL OF ENGINE PARTS

Before starting any maintenance works try to track the fault cause. Decide whether the removal or disassembly of the part in question is necessary.

CLEANING OF REUSABLE PARTS

All reusable parts have to be cleaned carefully and thoroughly and in a suitable way.

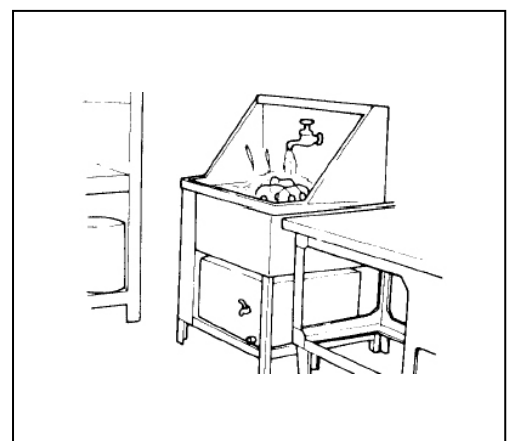

SPARE PARTS

If parts have to be replaced, use original CPI spare parts only.

REASSEMBLY

If reassembling engine parts, precisely obey the instructions regarding defaults of tightening torques and other settings. The following parts always have to be replaced prior to reassembly.

1. Oil retainers
2. Washers
3. O-rings
4. Lock washers
5. Split cotter pins
6. Plastic nuts

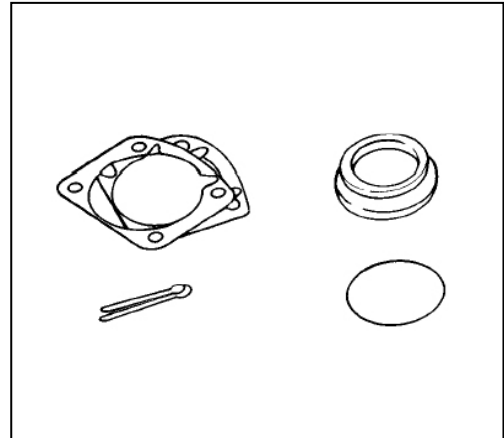

Depending on the mounting place the following should be carried out:

1. Applying sealant to washers.
2. Oiling of moveable parts.
3. Oil or lubricating grease must be applied to defined spots (e.g. oil retainers) prior to assembling.

ELECTRICAL EQUIPMENT

1. Always disconnect the cable from the battery's (-) negative terminal first.
2. Never pull the cable when disconnecting connections. Always remove plugs by pulling the plug.
3. Snap-in connections are properly made when you can hear a click noise.
4. Sensors and relays have to be handled carefully. Do not drop them and avoid contact with other parts.

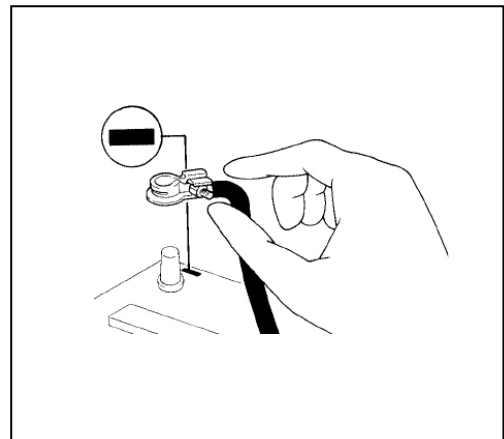
**RUBBER PARTS, RUBBER-SHEATED CABLES, AND RUBBER TUBES**

Pay attention not to wet rubber parts, rubber-sheated cables, and rubber tubes with petrol or oil.

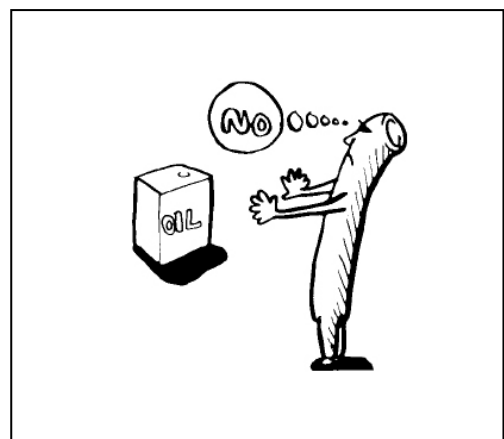

MAINTAINING THE ELECTRICAL SYSTEM

1. Prior to maintaining the electrical system, the ignition has to be switched off and the battery ground cable has to be disconnected.
2. To avoid slack, wiring harnesses have to be fixed with cable clamps or cable fastening ribbons. However, allow a little play to all wiring harnesses, which are routed to the engine or other vibrating vehicle parts. This play must be in such a way that the wiring harnesses do not contact adjacent parts due to engine vibrations.
3. If any part of a wiring harness is routed along an edge or corner of a vehicle part, or if it has contact to that edge or corner, that section of the harness has to be wrapped round with tape or the like in order to protect it against damage.
4. When mounting or reinstalling vehicle parts, pay attention not to pinch or damage any of the wiring harnesses.

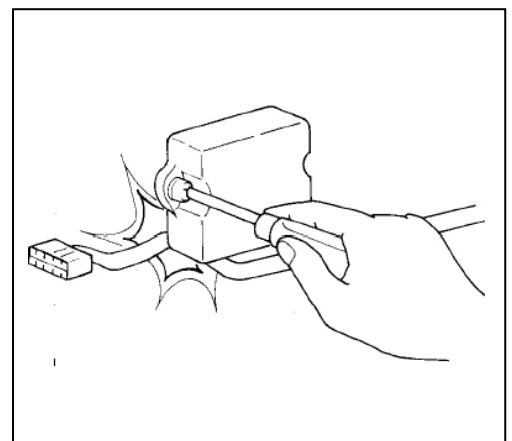
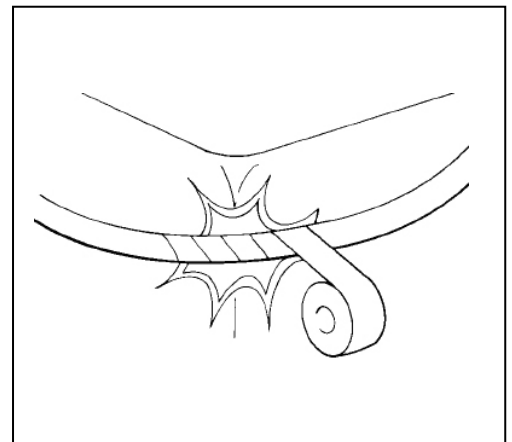
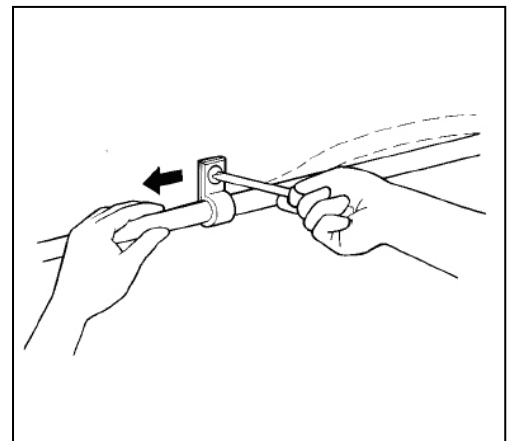
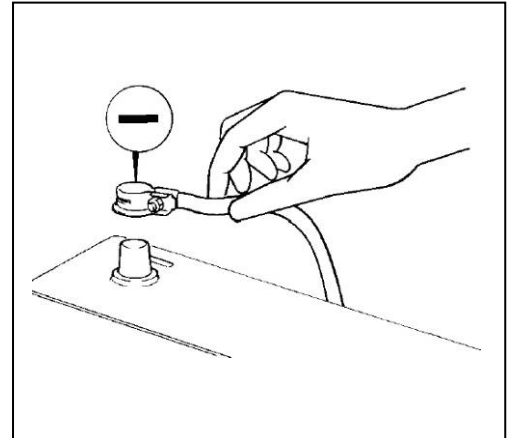

5. Do not drop relays, sensors, or other electric components and do not expose them to vibration.

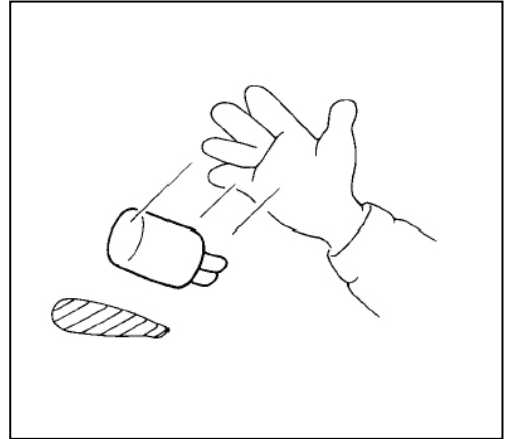

6. Electric component parts built in the microcomputer or relay are sensitive to heat and can easily get damaged. If for maintenance works the temperature must be risen above 80 °C, those electric component parts have to be removed prior to maintenance.

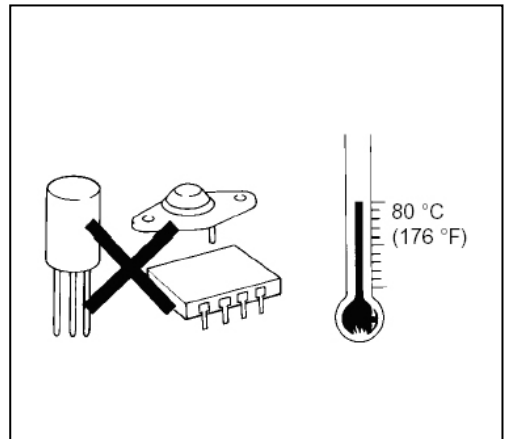

7. Loose coupling can cause malfunctions. Make sure that all plug-connections are adequately made.

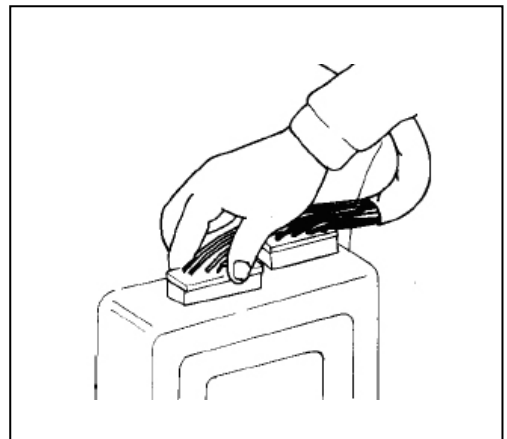

8. Always pull the connector and not the wiring harness when disconnecting any plug connections.

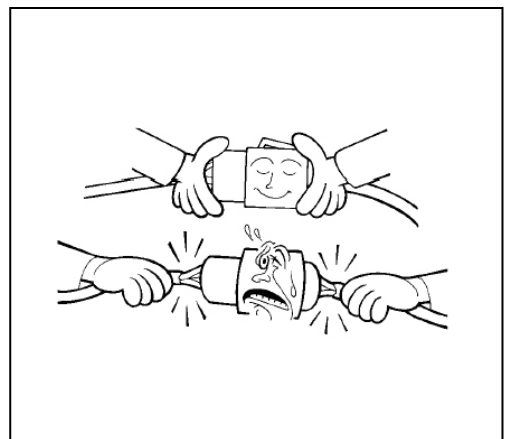

9. If snap-in connections have latching clips, those connections can be interrupted by pressing the clips down according to the directions specified in the adjacent drawing.

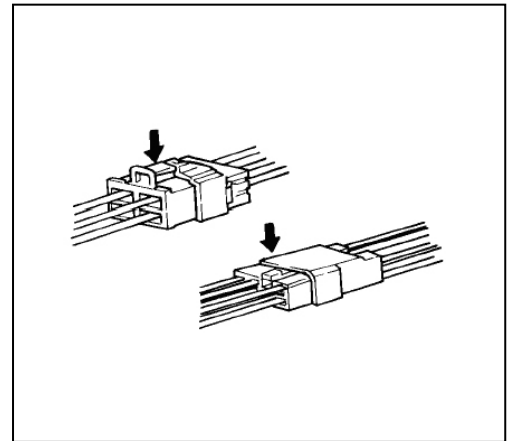

10. The latching clips are properly locked in place when you can hear a click noise.

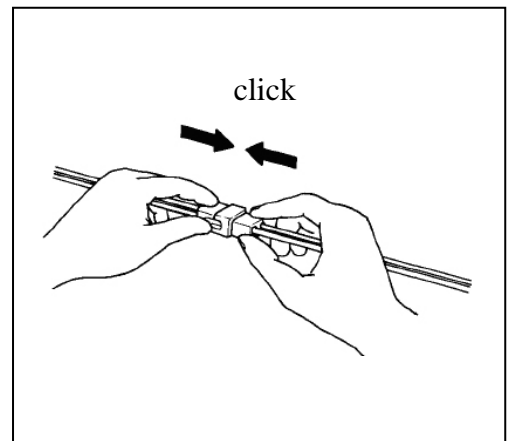

11. When conducting continuity checks or voltage measurements with a circuit tester, the test probe must be inserted in the terminals at the wiring harness side. In the case of a shielded connection the probe must be inserted through the cable opening of the rubber cap until contact is made with the terminal. Pay attention not to damage the insulation and wires.

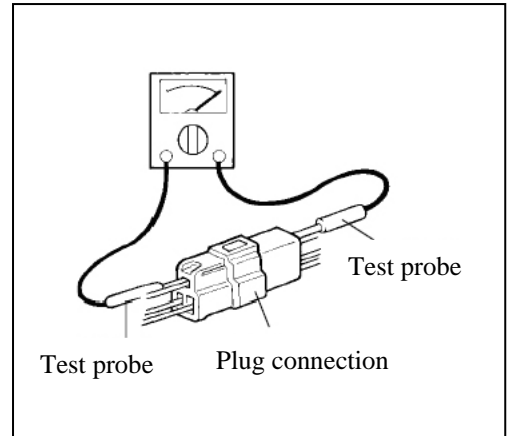

12. Take into account the electric load caused by additional equipment in order to avoid wiring overload.

TECHNICAL DATA

SPECIFICATIONS	TD 2
ARAGON GP 45 KM/H	TD-2
ARAGON GP 30 KM/H	TD-4
ARAGON GP 25 KM/H	TD-6
ARAGON 45 KM/H	TD-8
ARAGON 30 KM/H	TD-10
ARAGON 25 KM/H	TD-12
FORMULA R 45 KM/H	TD-14
FORMULA R 30 KM/H	TD-16
FORMULA R 25 KM/H	TD-18

SPECIFICATIONS

Aragon GP 45km/h

Engine:		
Nominal power (EEC)	2,9 / 6000	[kW/min ⁻¹]
Nominal torque (EEC)	4,9 / 6000	[Nm]
Bore / Stroke	40 / 39,2	[mm]
Compression ratio	7,8	
Compression pressure (hot)	---	[bar/min ⁻¹]
Piston clearance, max.	0,085	[mm]
Piston ring gap, max.	0,4	[mm]

Fuel supply & adjustments:		
Carburetor / Identification no.	Dell'Orto PHVA 16 / 08463	
Main jet	46	
Idling jet	36D	
Position jet needle	3	[from top]
Float chamber level	13 ± 0.5 not adjustable	[mm]
Air adjustment screw	½	[turns]
Idling speed	1800 ± 100	[min ⁻¹]
Automatic cold start equipment, stroke at 12V AC		
Working time	4 105	[mm/5 min] [sec.]

Tires & filling pressure:		
Front wheel	120 / 70 – 12 51J	
Rear wheel	130 / 70 – 12 56J	
Air pressure front	1,9	[bar]
Air pressure rear	2,0	[bar]

Filling quantities & specifications:		
Fuel (unleaded) 91 ROZ	7,9	[l]
Engine Oil	---	[l]
2 stroke oil (full synthetic)	1,4	[l]
Gearbox oil (SAE 80W90)	100	[ml]
Front fork oil (SAE 5W20)	100	[ml]
Brake fluid (DOT 4)	in case of need	

CVT:		
Roller weights	5,8	[g]
	12 x 15	[mm]

Torques:	[Ø mm]	[Nm]
Front axle nut	12	55
Rear axle nut	14	120
Screw front fork bridge	10	30
Screw brake calliper	8	40
Screw handle bar	10	50
Shock absorber lower fixing	8	25
Engine mounting screw	10	50
	12	55
Gearbox cover screw	8	20
Crankcase	6	10
Cylinder head	7	12
Flywheel	10	35
CVT fixing nut	10	35
Clutch fixing nut	10	45
Clutch pads fixing nut	28	45
Drain plug gearbox	8	15
CVT cover	6	12
Kick starter	6	12
Exhaust pipe	6	10
Silencer	8	30
Standard torque for screws and nuts without special function	12	60
	10	40
	8	25
	6	12
	5	4
Spark plug	14	15

Electrical assy:		
Battery charging voltage (Battery fully charged)	13,5 ± 0,5	[V]
Battery charging current (Battery empty)	1,8	[A]
Fuse	8	[A]
Bulb low beam	55 H1	
Bulb high beam	55 H1	[W]
Bulb position lamp	5	
Bulb rear- and stop lamp, License plate illumination	21 / 5	[W]
Bulb winker	---	[W]
Ignition pulse generator (blue/white-green/white)	340 ± 50	[Ω]
	1,5 / 1900	[V/ min ⁻¹]
Ignition coil ACG	900 ± 100	[Ω]
	125 / 800	[V/ min ⁻¹]
Charging coil (white) Plug disconnected Max. voltage	0,9	[Ω]
	22 / 2500	[V/ min ⁻¹]
	81 / 8500	[V/ min ⁻¹]
Light coil (green/white) Plug disconnected Max. voltage	0,8	[Ω]
	18 / 2500	[V/ min ⁻¹]
	69 / 8500	[V/ min ⁻¹]
Ignition coil primary	0,4 – 0,6	[Ω]
Ignition coil secondary	3 ± 0,5	[kΩ]
Spark plug connector	10	[kΩ]
Spark plug	BR7ES	[---]
Spark plug gap	0,7 – 0,8	[mm]
Spark gap	min.6	[mm]
Ignition point	17 / 1800	[°/min ⁻¹]
Distance between pickup and flywheel	0,6 – 0,8	[mm]

Aragon GP 30 km/h

Engine:		
Nominal power (EEC)	1,4 / 5000	[kW/min ⁻¹]
Nominal torque (EEC)	3,5 / 3000	[Nm]
Bore / Stroke	40 / 39,2	[mm]
Compression ratio	7,8	
Compression pressure (hot)	---	[bar/min ⁻¹]
Piston clearance, max.	0,085	[mm]
Piston ring gap, max.	0,4	[mm]

Fuel supply & adjustments:		
Carburetor / Identification no.	Dell'Orto PHVA 16 / 08461	
Main jet	46	
Idling jet	36	
Position jet needle	2	[from top]
Float chamber level	13 ± 0.5 not adjustable	[mm]
Air adjustment screw	½	[turns]
Idling speed	1800 ± 100	[min ⁻¹]
Automatic cold start equipment, stroke at 12V AC		
Working time	4	[mm/5 min]
	105	[sec.]

Tires & filling pressure:		
Front wheel	120 / 70 – 12 51J	
Rear wheel	130 / 70 – 12 56J	
Air pressure front	1,9	[bar]
Air pressure rear	2,0	[bar]

Filling quantities & specifications:		
Fuel (unleaded) 91 ROZ	7,9	[l]
Engine Oil	---	[l]
2 stroke oil (full synthetic)	1,4	[l]
Gearbox oil (SAE 80W90)	100	[ml]
Front fork oil (SAE 5W20)	100	[ml]
Brake fluid (DOT 4)	in case of need	

CVT:		
Roller weights	6,3	[g]
	12 x 15	[mm]

Torques:	[Ø mm]	[Nm]
Front axle nut	12	55
Rear axle nut	14	120
Screw front fork bridge	10	30
Screw brake calliper	8	40
Screw handle bar	10	50
Shock absorber lower fixing	8	25
Engine mounting screw	10	50
	12	55
Gearbox cover screw	8	20
Crankcase	6	10
Cylinder head	7	12
Flywheel	10	35
CVT fixing nut	10	35
Clutch fixing nut	10	45
Clutch pads fixing nut	28	45
Drain plug gearbox	8	15
CVT cover	6	12
Kick starter	6	12
Exhaust pipe	6	10
Silencer	8	30
Standard torque for screws and nuts without special function	12	60
	10	40
	8	25
	6	12
	5	4
Spark plug	14	15

Electrical assy:		
Battery charging voltage (Battery fully charged)	13,5 ± 0,5	[V]
Battery charging current (Battery empty)	1,8	[A]
Fuse	8	[A]
Bulb low beam	55 H1	
Bulb high beam	55 H1	[W]
Bulb position lamp	5	
Bulb rear- and stop lamp, License plate illumination	21 / 5	[W]
Bulb winker	---	[W]
Ignition pulse generator (blue/white-green/white)	340 ± 50	[Ω]
	1,5 / 1900	[V/ min ⁻¹]
Ignition coil ACG	900 ± 100	[Ω]
	125 / 800	[V/ min ⁻¹]
Charging coil (white) Plug disconnected Max. voltage	0,9	[Ω]
	22 / 2500	[V/ min ⁻¹]
	81 / 8500	[V/ min ⁻¹]
Light coil (green/white) Plug disconnected Max. voltage	0,8	[Ω]
	18 / 2500	[V/ min ⁻¹]
	69 / 8500	[V/ min ⁻¹]
Ignition coil primary	0,4 – 0,6	[Ω]
Ignition coil secondary	3 ± 0,5	[kΩ]
Spark plug connector	10	[kΩ]
Spark plug	BR7ES	[---]
Spark plug gap	0,7 – 0,8	[mm]
Spark gap	min.6	[mm]
Ignition point	17 / 1800	[°/min ⁻¹]
Distance between pickup and flywheel	0,6 – 0,8	[mm]

Aragon GP 25 km/h

Engine:		
Nominal power (EEC)	1,4 / 5000	[kW/min ⁻¹]
Nominal torque (EEC)	3,5 / 3000	[Nm]
Bore / Stroke	40 / 39,2	[mm]
Compression ratio	7,8	
Compression pressure (hot)	---	[bar/min ⁻¹]
Piston clearance, max.	0,085	[mm]
Piston ring gap, max.	0,4	[mm]

Fuel supply & adjustments:		
Carburetor / Identification no.	Dell'Orto PHVA 16 / 08461	
Main jet	46	
Idling jet	36	
Position jet needle	2	[from top]
Float chamber level	13 ± 0.5 not adjustable	[mm]
Air adjustment screw	½	[turns]
Idling speed	2000 ± 100	[min ⁻¹]
Automatic cold start equipment, stroke at 12V AC		
Working time	4 105	[mm/5 min] [sec.]

Tires & filling pressure:		
Front wheel	120 / 70 – 12 51J	
Rear wheel	130 / 70 – 12 56J	
Air pressure front	1,9	[bar]
Air pressure rear	2,0	[bar]

Filling quantities & specifications:		
Fuel (unleaded) 91 ROZ	7,9	[l]
Engine Oil	---	[l]
2 stroke oil (full synthetic)	1,4	[l]
Gearbox oil (SAE 80W90)	100	[ml]
Front fork oil (SAE 5W20)	100	[ml]
Brake fluid (DOT 4)	in case of need	

CVT:		
Roller weights	6,3	[g]
	12 x 15	[mm]

Torques:	[Ø mm]	[Nm]
Front axle nut	12	55
Rear axle nut	14	120
Screw front fork bridge	10	30
Screw brake calliper	8	40
Screw handle bar	10	50
Shock absorber lower fixing	8	25
Engine mounting screw	10	50
	12	55
Gearbox cover screw	8	20
Crankcase	6	10
Cylinder head	7	12
Flywheel	10	35
CVT fixing nut	10	35
Clutch fixing nut	10	45
Clutch pads fixing nut	28	45
Drain plug gearbox	8	15
CVT cover	6	12
Kick starter	6	12
Exhaust pipe	6	10
Silencer	8	30
Standard torque for screws and nuts without special function	12	60
	10	40
	8	25
	6	12
	5	4
Spark plug	14	15

Electrical assy:		
Battery charging voltage (Battery fully charged)	13,5 ± 0,5	[V]
Battery charging current (Battery empty)	1,8	[A]
Fuse	8	[A]
Bulb low beam	55 H1	
Bulb high beam	55 H1	[W]
Bulb position lamp	5	
Bulb rear- and stop lamp, License plate illumination	21/5	[W]
Bulb winker	---	[W]
Ignition pulse generator (blue/white-green/white)	340 ± 50	[Ω]
	1,5 / 1900	[V/ min ⁻¹]
Ignition coil ACG	900 ± 100	[Ω]
	125 / 800	[V/ min ⁻¹]
Charging coil (white) Plug disconnected Max. voltage	0,9	[Ω]
	22 / 2500	[V/ min ⁻¹]
	81 / 8500	[V/ min ⁻¹]
Light coil (green/white) Plug disconnected Max. voltage	0,8	[Ω]
	18 / 2500	[V/ min ⁻¹]
	69 / 8500	[V/ min ⁻¹]
Ignition coil primary	0,4 – 0,6	[Ω]
Ignition coil secondary	3 ± 0,5	[kΩ]
Spark plug connector	10	[kΩ]
Spark plug	BR7ES	[---]
Spark plug gap	0,7 – 0,8	[mm]
Spark gap	min.6	[mm]
Ignition point	17 / 1800	[°/min ⁻¹]
Distance between pickup and flywheel	0,6 – 0,8	[mm]

Aragon 45 km/h

Engine:		
Nominal power (EEC)	2,4 / 5900	[kW/min ⁻¹]
Nominal torque (EEC)	4,0 / 5400	[Nm]
Bore / Stroke	40,0 / 39,2	[mm]
Compression ratio	7,8	
Compression pressure (hot)	---	[bar/min ⁻¹]
Piston clearance, max.	0,1	[mm]
Piston ring gap, max.	0,4	[mm]

Fuel supply & adjustments:		
Carburetor / Identification no.	Dell'Orto PHVA 16 / 08456	
Main jet	52	
Idling jet	36D	
Position jet needle	2	[from top]
Float chamber level	13 ± 0,5 not adjustable	[mm]
Air adjustment screw	½	[turns]
Idling speed	1800 ± 100	[min ⁻¹]
Automatic cold start equipment, stroke at 12V AC		
Working time	4	[mm/5 min]
	105	[sec.]

Tires & filling pressure:		
Front wheel	120 / 70 – 12 51J	
Rear wheel	130 / 70 – 12 56J	
Air pressure front	1,9	[bar]
Air pressure rear	2,0	[bar]

Filling quantities & specifications:		
Fuel (unleaded) 91 ROZ	7,9	[l]
Engine Oil	---	[l]
2 stroke oil (full synthetic)	1,4	[l]
Gearbox oil (SAE 80W90)	100	[ml]
Front fork oil (SAE 5W20)	100	[ml]
Brake fluid (DOT 4)	in case of need	

Fuel supply & adjustments:		
Carburetor	Mikuni VM 16mm Ø	
Main jet	47,5	
Idling jet	15	
Position jet needle	2	[from top]
Float chamber level	14 ± 0,5	[mm]
Air adjustment screw	½	[turns]
Idling speed	1800 ± 100	[min ⁻¹]
Automatic cold start equipment, stroke at 12V AC		
Working time	4	[mm/5 min]
	125	[sec.]

CVT:		
Roller weights	6,3	[g]
	12 x 15	[mm]

Torques:	[Ø mm]	[Nm]
Front axle nut	12	55
Rear axle nut	14	120
Screw front fork bridge	10	30
Screw brake calliper	8	40
Screw handle bar	10	50
Shock absorber lower fixing	8	25
Engine mounting screw	10	50
	12	55
Gearbox cover screw	8	20
Crankcase	6	10
Cylinder head	7	12
Flywheel	10	35
CVT fixing nut	10	35
Clutch fixing nut	10	45
Clutch pads fixing nut	28	45
Drain plug gearbox	8	15
CVT cover	6	12
Kick starter	6	12
Exhaust pipe	6	10
Silencer	8	30
Standard torque for screws and nuts without special function	12	60
	10	40
	8	25
	6	12
	5	4
Spark plug	14	15

Electrical assy:		
Battery charging voltage (Battery fully charged)	13,5 ± 0,5	[V]
Battery charging current (Battery empty)	1,8	[A]
Fuse	8	[A]
Bulb low beam	55 H1	
Bulb high beam	55 H1	[W]
Bulb position lamp	5	
Bulb rear- and stop lamp, License plate illumination	21 / 5	[W]
Bulb winker	LED	[W]
Ignition pulse generator (blue/white-green/white)	340 ± 50	[Ω]
	1,5 / 1900	[V/ min ⁻¹]
Ignition coil ACG	900 ± 100	[Ω]
	125 / 800	[V/ min ⁻¹]
Charging coil (white) Plug disconnected Max. voltage	0,9	[Ω]
	22 / 2500	[V/ min ⁻¹]
	81 / 8500	[V/ min ⁻¹]
Light coil (green/white) Plug disconnected Max. voltage	0,8	[Ω]
	18 / 2500	[V/ min ⁻¹]
	69 / 8500	[V/ min ⁻¹]
Ignition coil primary	0,4 – 0,6	[Ω]
Ignition coil secondary	3 ± 0,5	[kΩ]
Spark plug connector	10	[kΩ]
Spark plug	BR7ES	[---]
Spark plug gap	0,7 – 0,8	[mm]
Spark gap	min.6	[mm]
Ignition point	17 / 1800	[°/min ⁻¹]
Distance between pickup and flywheel	0,6 – 0,8	[mm]

Aragon 30 km/h

Engine:		
Nominal power (EEC)	1,5 / 4500	[kW/min ⁻¹]
Nominal torque (EEC)	3,1 / 4500	[Nm]
Bore / Stroke	40 / 39,2	[mm]
Compression ratio	7,8	
Compression pressure (hot)	---	[bar/min ⁻¹]
Piston clearance, max.	0,1	[mm]
Piston ring gap, max.	0,4	[mm]

Fuel supply & adjustments:		
Carburetor / Identification no.	Dell'Orto PHVA 16 / 08458	
Main jet	46	
Idling jet	36	
Position jet needle	2	[from top]
Float chamber level	13 ± 0.5 not adjustable	[mm]
Air adjustment screw	½	[turns]
Idling speed	2000 ± 100	[min ⁻¹]
Automatic cold start equipment, stroke at 12V AC		
Working time	4 105	[mm/5 min] [sec.]

Tires & filling pressure:		
Front wheel	120 / 70 – 12 51J	
Rear wheel	130 / 70 – 12 56J	
Air pressure front	1,9	[bar]
Air pressure rear	2,0	[bar]

Filling quantities & specifications:		
Fuel (unleaded) 91 ROZ	7,9	[l]
Engine Oil	---	[l]
2 stroke oil (full synthetic)	1,4	[l]
Gearbox oil (SAE 80W90)	100	[ml]
Front fork oil (SAE 5W20)	100	[ml]
Brake fluid (DOT 4)	in case of need	

CVT:		
Roller weights	6,3	[g]
	12 x 15	[mm]

Torques:	[Ø mm]	[Nm]
Front axle nut	12	55
Rear axle nut	14	120
Screw front fork bridge	10	30
Screw brake calliper	8	40
Screw handle bar	10	50
Shock absorber lower fixing	8	25
Engine mounting screw	10	50
	12	55
Gearbox cover screw	8	20
Crankcase	6	10
Cylinder head	7	12
Flywheel	10	35
CVT fixing nut	10	35
Clutch fixing nut	10	45
Clutch pads fixing nut	28	45
Drain plug gearbox	8	15
CVT cover	6	12
Kick starter	6	12
Exhaust pipe	6	10
Silencer	8	30
Standard torque for screws and nuts without special function	12	60
	10	40
	8	25
	6	12
	5	4
Spark plug	14	15

Electrical assy:		
Battery charging voltage (Battery fully charged)	13,5 ± 0,5	[V]
Battery charging current (Battery empty)	1,8	[A]
Fuse	8	[A]
Bulb low beam	55 H1	
Bulb high beam	55 H1	[W]
Bulb position lamp	5	
Bulb rear- and stop lamp, License plate illumination	21 / 5	[W]
Bulb winker	---	[W]
Ignition pulse generator (blue/white-green/white)	340 ± 50	[Ω]
	1,5 / 1900	[V/ min ⁻¹]
Ignition coil ACG	900 ± 100	[Ω]
	125 / 800	[V/ min ⁻¹]
Charging coil (white) Plug disconnected Max. voltage	0,9	[Ω]
	22 / 2500	[V/ min ⁻¹]
	81 / 8500	[V/ min ⁻¹]
Light coil (green/white) Plug disconnected Max. voltage	0,8	[Ω]
	18 / 2500	[V/ min ⁻¹]
	69 / 8500	[V/ min ⁻¹]
Ignition coil primary	0,4 – 0,6	[Ω]
Ignition coil secondary	3 ± 0,5	[kΩ]
Spark plug connector	10	[kΩ]
Spark plug	BR7ES	[---]
Spark plug gap	0,7 – 0,8	[mm]
Spark gap	min.6	[mm]
Ignition point	17 / 1800	[°/min ⁻¹]
Distance between pickup and flywheel	0,6 – 0,8	[mm]

Aragon 25 km/h

Engine:		
Nominal power (EEC)	1,5 / 4500	[kW/min ⁻¹]
Nominal torque (EEC)	3,1 / 4500	[Nm]
Bore / Stroke	40 / 39,2	[mm]
Compression ratio	7,8	
Compression pressure (hot)	---	[bar/min ⁻¹]
Piston clearance, max.	0,1	[mm]
Piston ring gap, max.	0,4	[mm]

Fuel supply & adjustments:		
Carburetor / Identification no.	Dell'Orto PHVA 16 / 08457	
Main jet	46	
Idling jet	36	
Position jet needle	2	[from top]
Float chamber level	13 ± 0.5	[mm]
Air adjustment screw	½	[turns]
Idling speed	2000 ± 100	[min ⁻¹]
Automatic cold start equipment, stroke at 12V AC		
Working time	4	[mm/5 min]
	105	[sec.]

Tires & filling pressure:		
Front wheel	120 / 70 – 12 51J	
Rear wheel	130 / 70 – 12 56J	
Air pressure front	1,9	[bar]
Air pressure rear	2,0	[bar]

Filling quantities & specifications:		
Fuel (unleaded) 91 ROZ	7,9	[l]
Engine Oil	---	[l]
2 stroke oil (full synthetic)	1,4	[l]
Gearbox oil (SAE 80W90)	100	[ml]
Front fork oil (SAE 5W20)	100	[ml]
Brake fluid (DOT 4)	in case of need	

Fuel supply & adjustments:		
Carburetor / Identification no.	Mikuni VM 16mm Ø	
Main jet	47,5	
Idling jet	15	
Position jet needle	2	[from top]
Float chamber level	14 ± 0.5	[mm]
Air adjustment screw	½	[turns]
Idling speed	2000 ± 100	[min ⁻¹]
Automatic cold start equipment, stroke at 12V AC		
Working time	4	[mm/5 min]
	125	[sec.]

CVT:		
Roller weights	6,3	[g]
	12 x 15	[mm]

Torques:	[Ø mm]	[Nm]
Front axle nut	12	55
Rear axle nut	14	120
Screw front fork bridge	10	30
Screw brake calliper	8	40
Screw handle bar	10	50
Shock absorber lower fixing	8	25
Engine mounting screw	10	50
	12	55
Gearbox cover screw	8	20
Crankcase	6	10
Cylinder head	7	12
Flywheel	10	35
CVT fixing nut	10	35
Clutch fixing nut	10	45
Clutch pads fixing nut	28	45
Drain plug gearbox	8	15
CVT cover	6	12
Kick starter	6	12
Exhaust pipe	6	10
Silencer	8	30
Standard torque for screws and nuts without special function	12	60
	10	40
	8	25
	6	12
	5	4
Spark plug	14	15

Electrical assy:		
Battery charging voltage (Battery fully charged)	13,5 ± 0,5	[V]
Battery charging current (Battery empty)	1,8	[A]
Fuse	8	[A]
Bulb low beam	55 H1	
Bulb high beam	55 H1	[W]
Bulb position lamp	5	
Bulb rear- and stop lamp, License plate illumination	21 / 5	[W]
Bulb winker	---	[W]
Ignition pulse generator (blue/white-green/white)	340 ± 50	[Ω]
	1,5 / 1900	[V/ min ⁻¹]
Ignition coil ACG	900 ± 100	[Ω]
	125 / 800	[V/ min ⁻¹]
Charging coil (white) Plug disconnected Max. voltage	0,9	[Ω]
	22 / 2500	[V/ min ⁻¹]
	81 / 8500	[V/ min ⁻¹]
Light coil (green/white) Plug disconnected Max. voltage	0,8	[Ω]
	18 / 2500	[V/ min ⁻¹]
	69 / 8500	[V/ min ⁻¹]
Ignition coil primary	0,4 – 0,6	[Ω]
Ignition coil secondary	3 ± 0,5	[kΩ]
Spark plug connector	10	[kΩ]
Spark plug	BR7ES	[---]
Spark plug gap	0,7 – 0,8	[mm]
Spark gap	min.6	[mm]
Ignition point	17 / 1800	[°/min ⁻¹]
Distance between pickup and flywheel	0,6 – 0,8	[mm]

Formula R 45 km/h

Engine:		
Nominal power (EEC)	2,4 / 5900	[kW/min ⁻¹]
Nominal torque (EEC)	4,0 / 5400	[Nm]
Bore / Stroke	40,0 / 39,2	[mm]
Compression ratio	8,4:1	---
Compression pressure (hot)	7,85 / 600	[bar/min ⁻¹]
Piston clearance, max.	0,10	[mm]
Piston ring gap, max.	0,40	[mm]
Piston ring (axial), max	---	---

Fuel supply & adjustments:		
Carburetor / Identification no.	Dell'Orto PHVA 16 / 08456	
Main jet	52	
Idling jet	36D	
Position jet needle	2	[from top]
Float chamber level	13 ± 0,5 not adjustable	[mm]
Air adjustment screw	½	[turns]
Idling speed	1800 ± 100	[min ⁻¹]
Automatic cold start equipment, stroke at 12V AC Working time	4 105	[mm/5 min] [sec.]

Tires & filling pressure:		
Front wheel	120 / 70 – 12 51J	
Rear wheel	130 / 70 – 12 56J	
Air pressure front	1,9	[bar]
Air pressure rear	2,0	[bar]

Filling quantities & specifications:		
Fuel (unleaded) 91 ROZ	5,2	[l]
Engine Oil	---	[l]
2 stroke oil (full synthetic)	1,4	[l]
Gearbox oil (SAE 80W90)	100	[ml]
Front fork oil (SAE 5W20)	100	[ml]
Brake fluid (DOT 4)	in case of need	
Coolant	---	[l]

CVT:		
Roller weights	6,3	[g]
	12 x 15	[mm]

Torques:	[Ø mm]	[Nm]
Front axle nut	12	55
Rear axle nut	14	120
Front fork upper fixing	---	---
Front fork lower fixing	10	20 / 30
Shock absorber upper fixing	10	30
Shock absorber lower fixing	8	25
Steering nut	10	50
Engine mounting screw	10	50
	12	55
Crankcase	6	10
Cylinder head	7	15
Flywheel	10	35
Drain plug gearbox	8	15
Exhaust pipe	6	10
Silencer	8	30
Standard torque for screws and nuts without special function	12	60
	10	40
	8	25
	6	12
	5	4
Spark plug	14	15

Electrical assy:		
Battery charging voltage (Battery fully charged)	14 ± 0,5	[V]
Battery charging current (Battery empty)	0,4	[A]
Fuse	8	[A]
Bulb headlamp	35 / 35 (S2)	[W]
License plate illumination	---	[W]
Bulb rear- and stop lamp	21 / 5	[W]
Bulb winker	10	[W]
Ignition pulse generator	500 ± 50	[Ω]
Ignition coil primary	0,3 – 0,5	[Ω]
Ignition coil secondary	1,4 ± 10%	[kΩ]
Spark plug connector	5	[kΩ]
Spark plug	BR7ES	--
Spark plug gap	0,7 – 0,8	[mm]
Spark gap	min. 6	[mm]
Ignition point	13 / 2000	[°/min ⁻¹]

Formula R 30 km/h

Engine:		
Nominal power (EEC)	1,5 / 4500	[kW/min ⁻¹]
Nominal torque (EEC)	3,1 / 4500	[Nm]
Bore / Stroke	40,0 / 39,2	[mm]
Compression ratio	8,4:1	---
Compression pressure (hot)	7,85 / 600	[bar/min ⁻¹]
Piston clearance, max.	0,10	[mm]
Piston ring gap, max.	0,70	[mm]
Piston ring (axial), max	---	---

Fuel supply & adjustments:		
Carburetor / Identification no.	Dell'Orto PHVA 16 / 08458	
Main jet	46	
Idling jet	36	
Position jet needle	2	[from top]
Float chamber level	13 ± 0.5 not adjustable	[mm]
Air adjustment screw	½	[turns]
Idling speed	2000 ± 100	[min ⁻¹]
Automatic cold start equipment, stroke at 12V AC Working time	4 105	[mm/5 min] [sec.]

Tires & filling pressure:		
Front wheel	120 / 70 – 12 51J	
Rear wheel	130 / 70 – 12 56J	
Air pressure front	1,9	[bar]
Air pressure rear	2	[bar]

Filling quantities & specifications:		
Fuel (unleaded) 91 ROZ	5,2	[l]
Engine Oil	---	[l]
2 stroke oil (full synthetic)	1,4	[l]
Gearbox oil (SAE 80W90)	100	[ml]
Front fork oil (SAE 5W20)	100	[ml]
Brake fluid (DOT 4)	in case of need	---
Coolant	---	[l]

CVT:		
Roller weights	6,3	[g]
	12 x 15	[mm]

Torques:	[Ø mm]	[Nm]
Front axle nut	12	55
Rear axle nut	14	120
Front fork upper fixing	---	---
Front fork lower fixing	10	20 / 30
Shock absorber upper fixing	10	30
Shock absorber lower fixing	8	25
Steering nut	10	60
Engine mounting screw	10	50
	12	55
Crankcase	6	10
Cylinder head	7	15
Flywheel	10	35
Drain plug gearbox	8	15
Exhaust pipe	6	10
Silencer	8	30
Standard torque for screws and nuts without special function	12	60
	10	40
	8	25
	6	12
	5	4
Spark plug	14	15

Electrical assy:		
Battery charging voltage (Battery fully charged)	14 ± 0,5	[V]
Battery charging current (Battery empty)	0,4	[A]
Fuse	8	[A]
Bulb headlamp	35/35 (S2)	[W]
License plate illumination	---	[W]
Bulb rear- and stop lamp	21 / 5	[W]
Bulb winker	10	[W]
Ignition pulse generator	500 ± 50	[Ω]
Ignition coil primary	0,3 – 0,5	[Ω]
Ignition coil secondary	1,4±10%	[kΩ]
Spark plug connector	5	[kΩ]
Spark plug	BR7ES	--
Spark plug gap	0,7 – 0,8	[mm]
Spark gap	min. 6	[mm]
Ignition point	13°/2000	[°/min ⁻¹]

Formula R 25 km/h

Engine:		
Nominal power (EEC)	1,5 / 4500	[kW/min ⁻¹]
Nominal torque (EEC)	3,1 / 4500	[Nm]
Bore / Stroke	40,0 / 39,2	[mm]
Compression ratio	8,4:1	---
Compression pressure (hot)	7,85 / 600	[bar/min ⁻¹]
Piston clearance, max.	0,10	[mm]
Piston ring gap, max.	0,70	[mm]
Piston ring (axial), max	---	---

Fuel supply & adjustments:		
Carburetor / Identification no.	Dell'Orto PHVA 16 / 08457	
Main jet	46	
Idling jet	36	
Position jet needle	2	[from top]
Float chamber level	13 ± 0.5	[mm]
Air adjustment screw	½	[turns]
Idling speed	2000 ± 100	[min ⁻¹]
Automatic cold start equipment, stroke at 12V AC		
Working time	4	[mm/5 min]
	105	[sec.]

Fuel supply & adjustments:		
Carburetor	VM CPI	
Main jet	47,5	[#]
Idling jet	15	[#]
Position jet needle	2	[from top]
Float chamber level	14 ± 1	[mm]
Air adjustment screw	1	[turns]
Idling speed	1800 ± 100	[min ⁻¹]
Automatic cold start equipment, stroke at 12 V AC	4	[mm/5 min]

Tires & filling pressure:		
Front wheel	120 / 70 – 12 51J	
Rear wheel	130 / 70 – 12 56J	
Air pressure front	1,9	[bar]
Air pressure rear	2,0	[bar]

Filling quantities & specifications:		
Fuel (unleaded) 91 ROZ	5,2	[l]
Engine Oil	---	[l]
2 stroke oil (full synthetic)	1,4	[l]
Gearbox oil (SAE 80W90)	100	[ml]
Front fork oil (SAE 5W20)	100	[ml]
Brake fluid (DOT 4)	in case of need	
Coolant	---	[l]

CVT:		
Roller weights	6,3	[g]
	12 x 15	[mm]

Torques:	[Ø mm]	[Nm]
Front axle nut	12	55
Rear axle nut	14	120
Front fork upper fixing	---	---
Front fork lower fixing	10	20 / 30
Shock absorber upper fixing	10	30
Shock absorber lower fixing	8	25
Steering nut	10	50
Engine mounting screw	10	50
	12	55
Crankcase	6	10
Cylinder head	7	15
Flywheel	10	35
Drain plug gearbox	8	15
Exhaust pipe	6	10
Silencer	8	30
Standard torque for screws and nuts without special function	12	60
	10	40
	8	25
	6	12
	5	4
Spark plug	14	15

Electrical assy:		
Battery charging voltage (Battery fully charged)	14 ± 0,5	[V]
Battery charging current (Battery empty)	0,4	[A]
Fuse	8	[A]
Bulb headlamp	35 / 35 (S2)	[W]
License plate illumination	---	[W]
Bulb rear- and stop lamp	21 / 5	[W]
Bulb winker	10	[W]
Ignition pulse generator	500 ± 50	[Ω]
Ignition coil primary	0,3 – 0,5	[Ω]
Ignition coil secondary	1,4 ± 10%	[kΩ]
Spark plug connector	5	[kΩ]
Spark plug	BR7ES	--
Spark plug gap	0,7 – 0,8	[mm]
Spark gap	min. 6	[mm]
Ignition point	13 / 2000	[°/min ⁻¹]

SPECIAL TOOLS

DESCRIPTION AND USAGE

ST-2

DESCRIPTION AND USAGE

<i>Description</i>	<i>Part number</i>	Intended purpose
Rotor puller	BEN-AB-09	Disassembling the rotor from the crankshaft
Core disconnecter	CPI-0011-31	Disconnecting the crankcase and removing the crankshaft. Disassembling the bearings from the crankshaft.
Universal fixing tool	DER-00005253240	Fixing the variomatic and the clutch
Assembling bush	CPI-000W-10	Assembling the left crankcase gasket
Assembling bush	CPI-000W-11	Assembling the right crankcase gasket
Con rod holder	DER-00G05600371	Fixing the conrod by diverse disassemblings
Temperature measuring chalk	DAE-TKF900120	Mounting the bearing in the crankcase
Spanner socket	DER-00G05300011	Fixing the fly wheel

CARBURETOR

SYSTEM OVERVIEW	FL-2
MAINTENANCE NOTICE	FL-3
TOOLS	FL-4
FAULT TRACKING	FL-4
CARBURETOR REMOVAL	FL-5
CHECKING TH CHOKE	FL-5
DISASSEMBLY	FL-7
FLOAT CHAMBER LEVEL	FL-7
SLIDE VALVE	FL-7
FACTORY DEFAULT	FL-8
REED-TYPE INLET-VALVE	FL-10

SYSTEM OVERVIEW

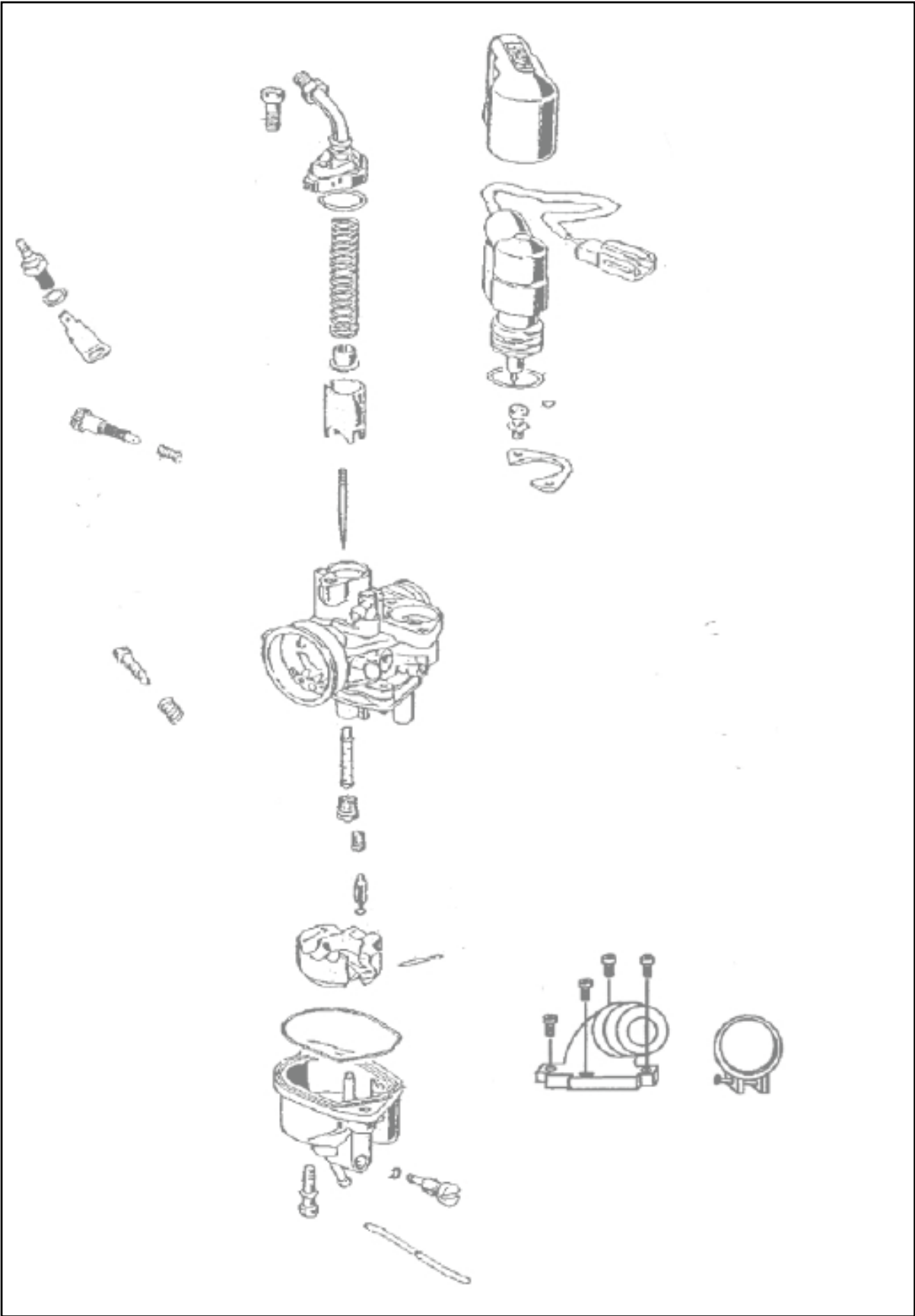

MAINTENANCE NOTICE

1. Before maintaining the carburetor, the engine, the fuel supply, and the ignition system have to be in a faultless state. The carburetor can only properly adjusted and faults in the carburetor system can be detected when there are no mechanical defects in the engine or defects in the fuel supply or in the ignition system.
 2. The engine must have warmed up and reached its operating temperature if the adjustments are to be made when the engine is running.
 3. The air cleaner has to be installed in the vehicle and the filter element must be clean.
 4. Observe that control cables are not kinked or heavily bent in order to ensure a proper carburetor adjustment.
 5. If for maintenance works the engine must run, pay attention to sufficient ventilation in closed rooms. Use suitable suctioning units to derive engine exhaust gases. Engine exhaust gases contain carbon monoxide and can lead to the unconsciousness and to death.
 6. Petrol is bad for health and can cause skin cancer. Any unnecessary skin contact has to be avoided.
 7. Used fuels are hazardous waste. They have to be disposed carefully and in line with the local regulations.
 8. Avoid flying sparks, open flames or smoking when working with fuel.
 9. If necessary, mark the position of pipings and their supports prior to dismantling. This makes the later reinstallation easier.
 10. Always use a new seal when installing the float chamber cover to the carburetor body.
 11. The carburetor float chamber is provided with a fuel drain screw. If the vehicle is not moved for more than one month, the fuel has to be drained completely. Otherwise, there will be danger of clogging of bores and jets, which in turn can lead to bad start behaviors or to malfunctions.
 12. Dried fuel can cause clogging of needle jets bores and channels in the float chamber or the carburetor body. They must be blown through with compressed air. Do not use needles or the like to clean the bores since this will damage or enlarge them.
-

TOOLS

- Standard tools

FAULT TRACKING

Bad start behavior, stall,

- Wrong idle speed adjustment
- Mixture too rich, too lean
- Air cleaner clogged or soiled
- Choke system defective
- Carburetor float chamber level wrongly adjusted

A/F mixture too lean

- Carburetor jets / bores clogged
- Fuel tank ventilation (fuel filler cap) clogged
- Clogged fuel supply (filter clogged, supply line squeezed)
- Carburetor float needle valve hangs, does not open
- Carburetor float chamber level too low
- Engine vacuums parasitic air
- Air cleaner body leaky

A/F mixture too rich

- Choke valve clogged
 - Nozzles clogged
 - Carburetor float needle valve hangs, does not open (due to soiling)
 - Carburetor float chamber level too high
 - Air cleaner clogged
-

CARBURETOR REMOVAL

Remove the helmet box.
Remove the air filter container.
Put out the cold start valve.
Remove the throttle control cable.
Remove the fuel line, the carburetor heating and the oil hose from the carburetor.
Release the pipe clamp from the air cleaner snorkel and remove the carburetor.



Drained fuel has to be properly disposed.



CHECKING THE CHOKE

Check the cables if they are conductive.

The resistance should be below 35 Ohm.

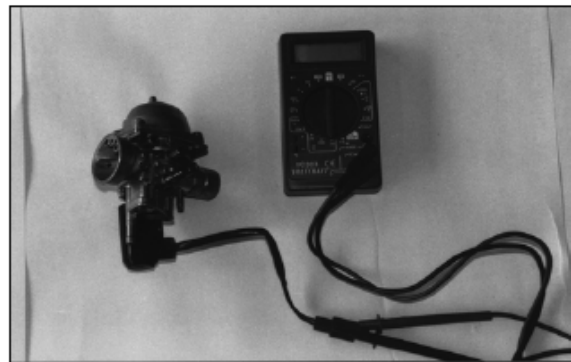

Remove and let cool down the carburetor.
Check the additional air bore (s. picture).
ok: when you are able to blow in
not ok: when you are not able to blow in.

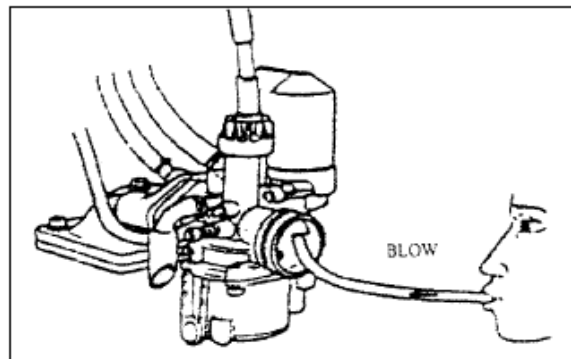

Connect the cold start valve to a charged battery for about 5 min.

Check the additional bore (s. picture).

ok: when you are able to blow in

not ok: when you are not able to blow.

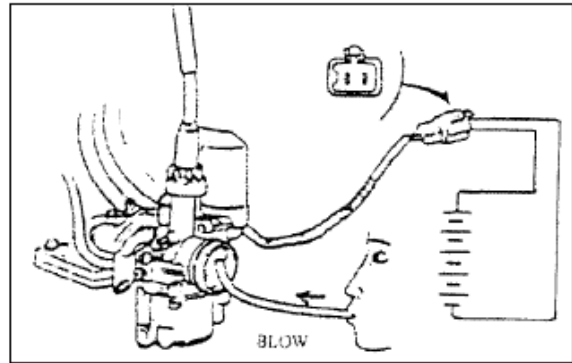

DISASSEMBLY

Release the fastening screws of the choke cable support bracket and remove the choke cable. Release the fastening screws of the float chamber cover and remove the float chamber cover.



When assembling the carburetor float chamber the seal will probably not fit since its material takes in fuel so that the seal swells. In this case the seal shall be dried in the sun. In most cases it can be reused.

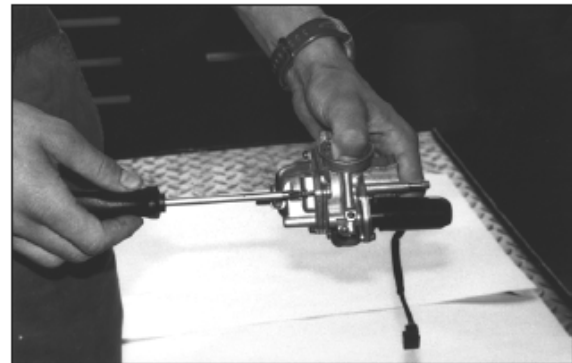

Drive out the float hinge pin with a suitable taper pin punch. Remove the float with the needle valve.

Unscrew the the main jet, the idle jet, the slide valve stop screw, and the idle screw.

Clean any deposits or cloggings in the the float chamber cover and bores with compressed air.



Make sure that all sealing rings and washers are removed as well. If they remain in the bores of the carburetor body, they might get lost during the cleaning with compressed air.



Danger of injury! Cover the carburetor with a rag during cleaning and wear safety goggles!

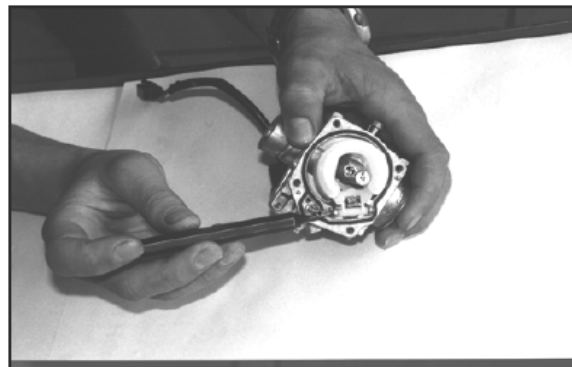

FLOAT CHAMBER LEVEL

Measure the float chamber with a caliper.

Desired value: 18.5 mm



Note that the float is entirely made of plastic. In case of any defects in this part, the float shall be replaced.

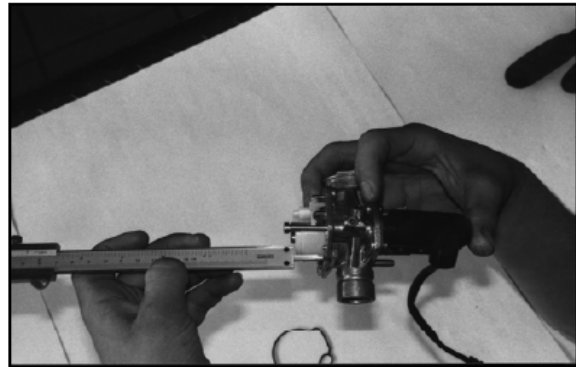

Use a new sealing ring prior to mounting the float chamber cover.

Mount the float chamber cover to the carburetor body.

Fasten the choke cable and put in the throttle control cable.

Check the oil and the fuel line, the overflow tube and the heating cable for damage and aging.

Connect all lines to the carburetor.

Adjust the throttle control cable.

Adjust the free play of the throttle control cable.



SLIDE VALVE

Disassembly

Release the screws in the carburetor cover.

Press the spring into the cover and remove the securing plastic stopper from the slide valve.

Then unhook the control cable from the slide valve. Remove the jet needle with the retaining clip.

Check the spring, the slide valve, and the plastic stopper for wear and the jet needle for deformation.

Check the needle jet for clogging.

Remove deposits and clogging by means of compressed air.



Position of the retaining clip

Check whether the retaining clip is seated in the default notch (counted from above) on the jet needle (see “technical data”).



The position of the retaining clip has influence on the A/F mixture when the engine is running at middle and upper load. Usually, a deviation from the above setting is not required, except for extreme operating conditions. Before changing the clip position on the jet needle, all other adjustments and possible failure sources have to be checked.



Note the different design of the carburetor covers of the 45 km/h variant and of the speed-limited variants (Aragon GP: 30 km/h and 25 km/h variants; Formula R and Aragon: 25 km/h). In the case of the latter variants, the stop collar in the carburetor cover prevents the slide valve from entirely opening so that not the full capacity of the A/F mixture can enter the carburetor.

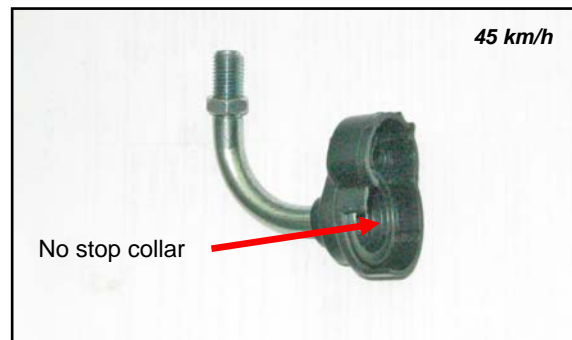
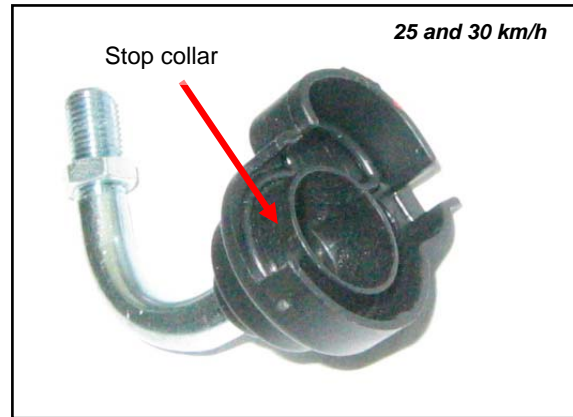

Assembly

Put the needle jet together with the retaining clip in the slide valve. Put the plastic stopper and the spring over the control cable and hook the cable in the slide valve.

Align the guide slot of the slide valve with the guide in the carburetor body (comp. photo).

Place the cover onto the carburetor and fasten the screws. Ensure a sufficient free play of the throttle control cable by adjusting the setting screw.



Pay attention not to attach the thread crookedly!

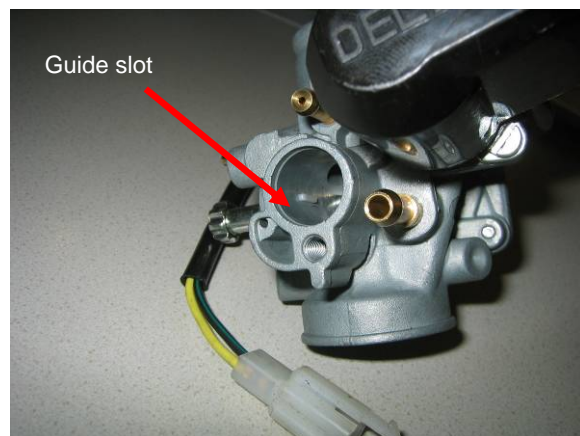

FACTORY DEFAULT

During the reassembly the carburetor shall be set to its factory default (1800 100 min^{-1} 100 min). Carefully turn the mixture control screw clockwise to the stop and then release it by 1.5 turns.

Turn the throttle grip and check whether the correct idle speed is adjusted by itself.

If the engine idle speed cannot be stabilized, then the position of the mixture control screw shall be changed in order to modify the composition of the A/F mixture.

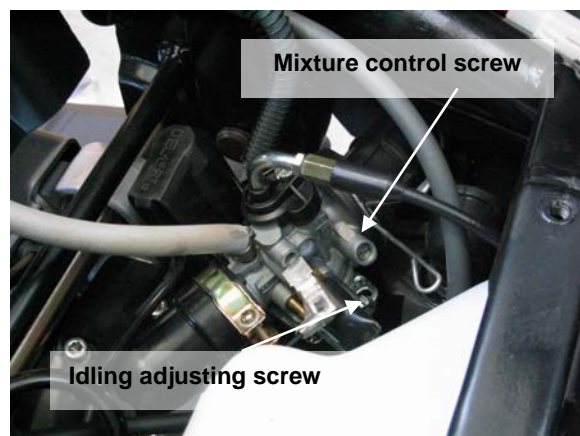

Mixture control screw

For the proper adjustment of the idle speed the engine must have reached its operating temperature.



Make sure that the vehicle consumers (e.g. headlight) are switched on prior to modifying the A/F mixture in order to ensure that idle speed will not drop below a level required for the proper vehicle operation.

If the mixture is too *lean*, the air adjustment screw shall be gradually screwed in clockwise by quarter turns.

When the idle speed decreases during this A/F mixture modification, the idle speed value has to be set back to the desired value. Carry out this adjustment by means of the idling adjusting speed.

If necessary, repeat this step every time the screw is turned in by a quarter turn.

If the mixture is too *rich*, the idle speed shall be modified accordingly. The mixture control screw shall be turned out anticlockwise while the desired idle speed value has to be set with the help of the idling adjusting screw.

REED-TYPE INLET VALVE

Remove the carburetor and the intake manifold by releasing the hose clamp of the intake manifold.

Check the intake manifold for crackings and fissures.



Any ageing cracks in the intake manifold can be very harmful to the engine as foreign air can be suctioned and will cause leaning.

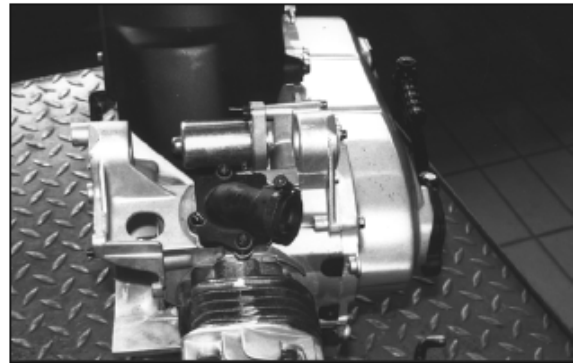

Notice the tear-off screw that is used for protecting the threaded connection. Cut a slit in the screw head in order to make the removal with a screwdriver easier.

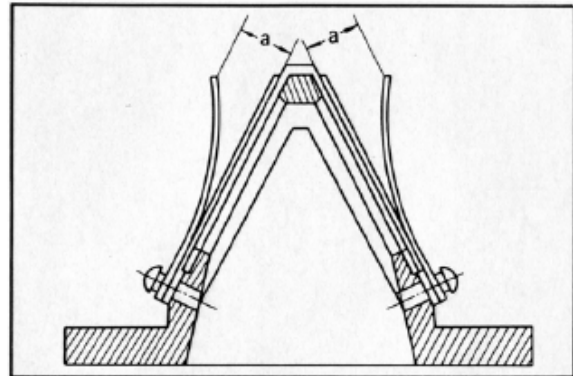

Remove the reed-type inlet valve and check the reeds for tightness.

Limit value: 0.1 mm

Also check the inlet valve for damage and replace it if necessary.

Install the inlet valve and the intake manifold in reverse order.



For the proper assembly of the threaded joint a new tear-off screw shall be used.

Check the firm fit of the intake manifold which connects the carburetor and the engine and make sure it is air-tight. Ensure that the clamp is securely tightened as well.

It is indispensable that the screws are fastened as per predefined torque in order to avoid that the rubber seal will be pressed out of position.

Intake manifold fastening screws torque: 12 Nm



After the installation of the carburetor all supply lines must be connected.

OIL PUMP

SYSTEM OVERVIEW	LB-2
REMOVAL	LB-3
INSPECTION	LB-3
INSTALLATION	LB-3
BLEEDING	LB-4

SYSTEM OVERVIEW

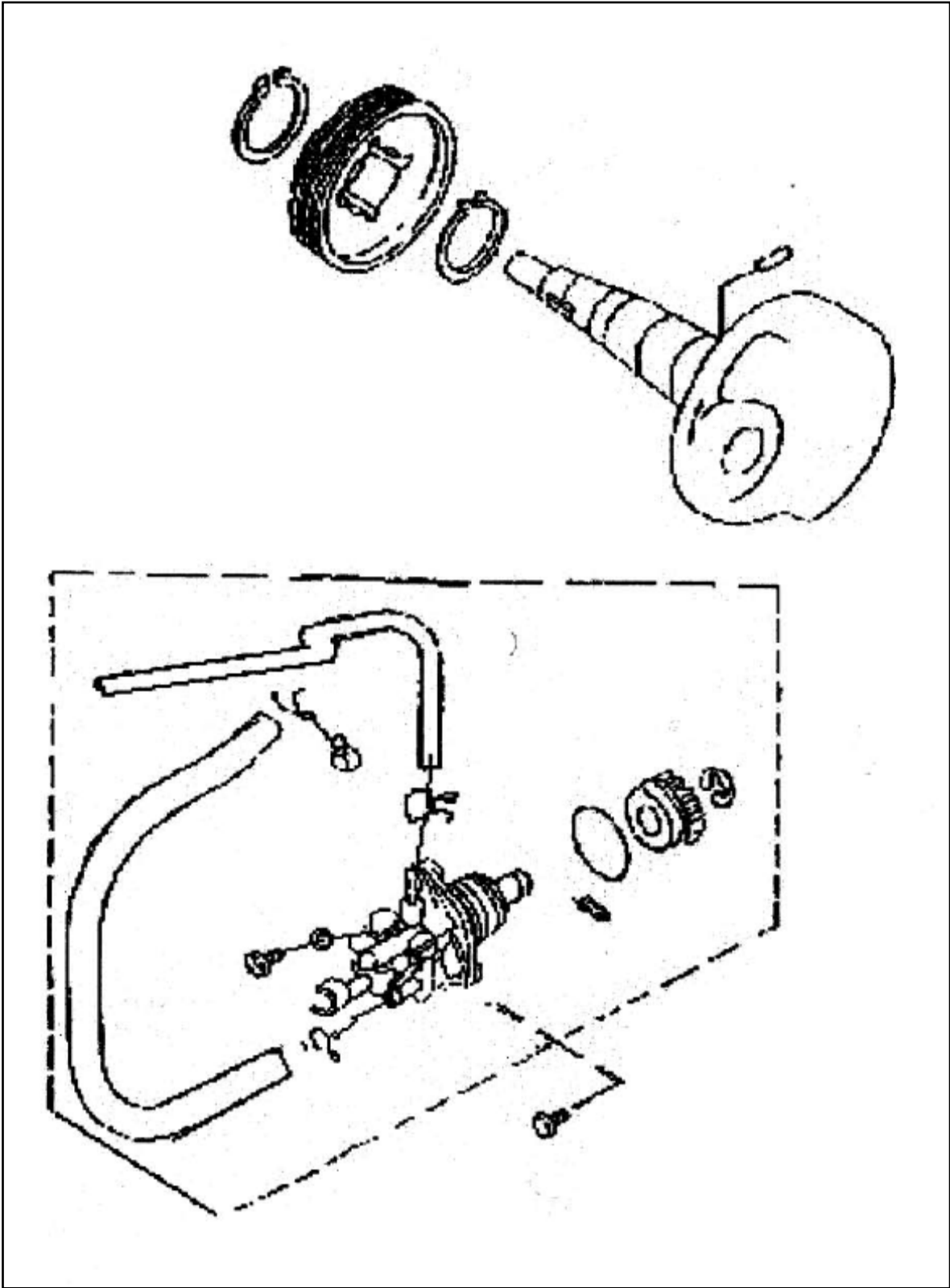

REMOVAL

Remove the underside paneling.
Remove the fan cover, the impeller, and the generator.

Remove the oil leads.

After removing the supply line from the oil reservoir and the delivery line, which leads to the carburetor, both lines must be plugged with suitable plugs so that no oil can flow out.

Unhook the oil pump control cable.

Loosen the fastening screws of the oil pump and remove the oil pump.

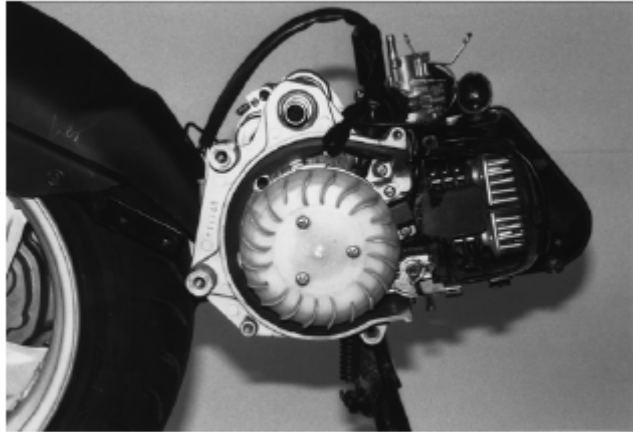

INSPECTION

Check the oil pump for leakage.
Check the O-ring, the drive sprocket and the shaft seal for wear and damage.
Check the driving tab for wear.



Do not dismantle the oil pump!

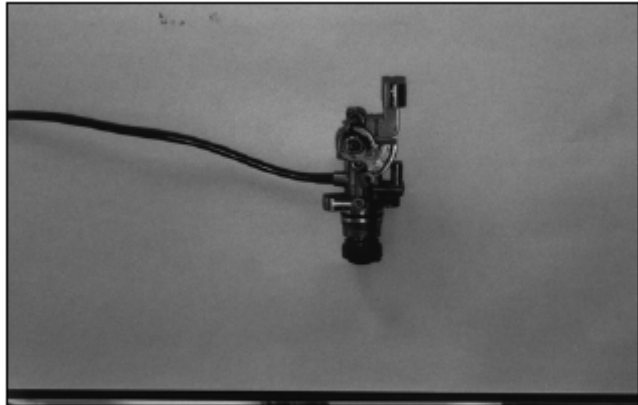

INSTALLATION

The O-ring seal has to be replaced prior to reinstalling. Provide the O-ring with clean oil.

Mount the oil pump in reverse order.

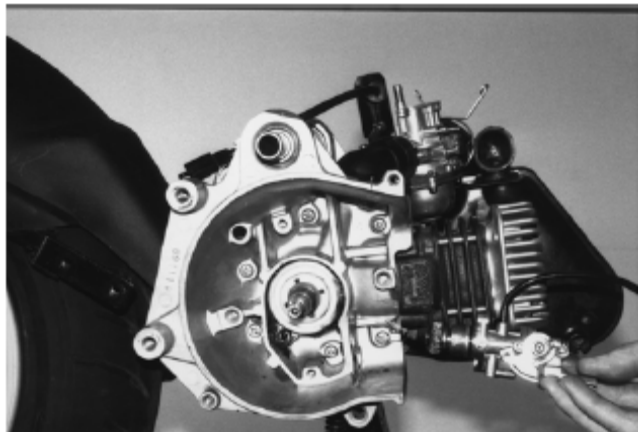

Connect the oil leads to the pump.
Hook in the control cable and adjust the cable play.
The lever must have a free travel α of 5-8°.
The allowable adjustment track to the full throttle position must be at least 70°.

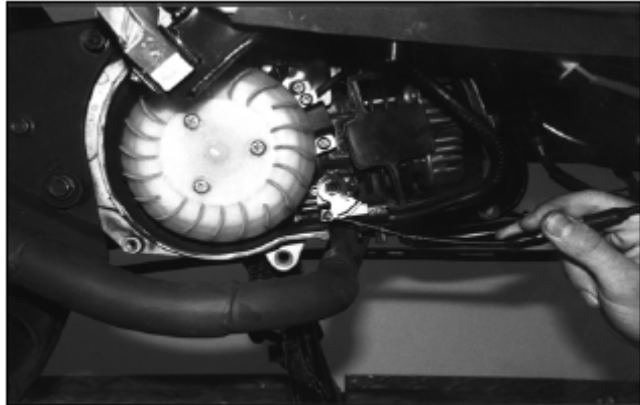

BLEEDING

The pump body and the delivery line must be bled subsequent to the reinstallation of the oil pump.

i During bleeding the engine should run with the correct oil/fuel mixture ratio in order to ensure that it is sufficiently lubricated.

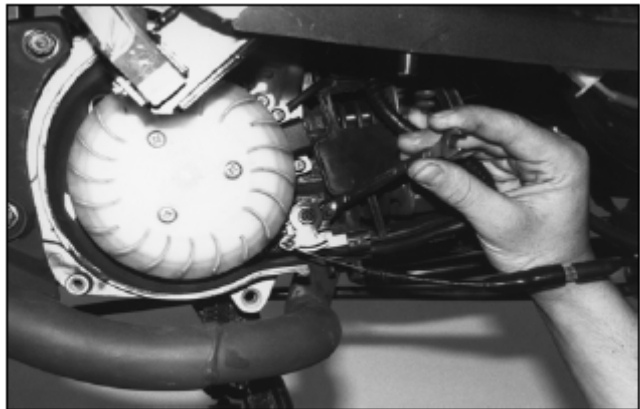

Loosen the bleeder bolt and wait until the oil drains out without bubbling.

Put the cable in the pump and adjust it as per marking. The minimum marking must be coherently oriented when the twist grip is closed, and the maximum marking must be coherently oriented when the grip is fully opened.

Remove the delivery line at the carburetor side and have the engine run until the oil runs out without bubbling.

Connect the delivery line and check the system for leakage.

Remove any oil residues from the engine and attached components.

CRANK DRIVE CRANKCASE CRANKSHAFT

SYSTEM OVERVIEW	CR-2
CYLINDER HEAD DISASSEMBLY	CR-3
CYLINDER DISASSEMBLY	CR-3
PISTON DISASSEMBLY	CR-4
PISTON ASSEMBLY	CR-7
CYLINDER ASSEMBLY	CR-7
COMPRESSION PRESSURE TESTING	CR-7
CRANKCASE / CRANKSHAFT	CR-8
DISMANTLING THE ENGINE CASE	CR-9
CRANKSHAFT	CR-9
ASSEMBLING THE CRANKCASE	CR-11

SYSTEM OVERVIEW

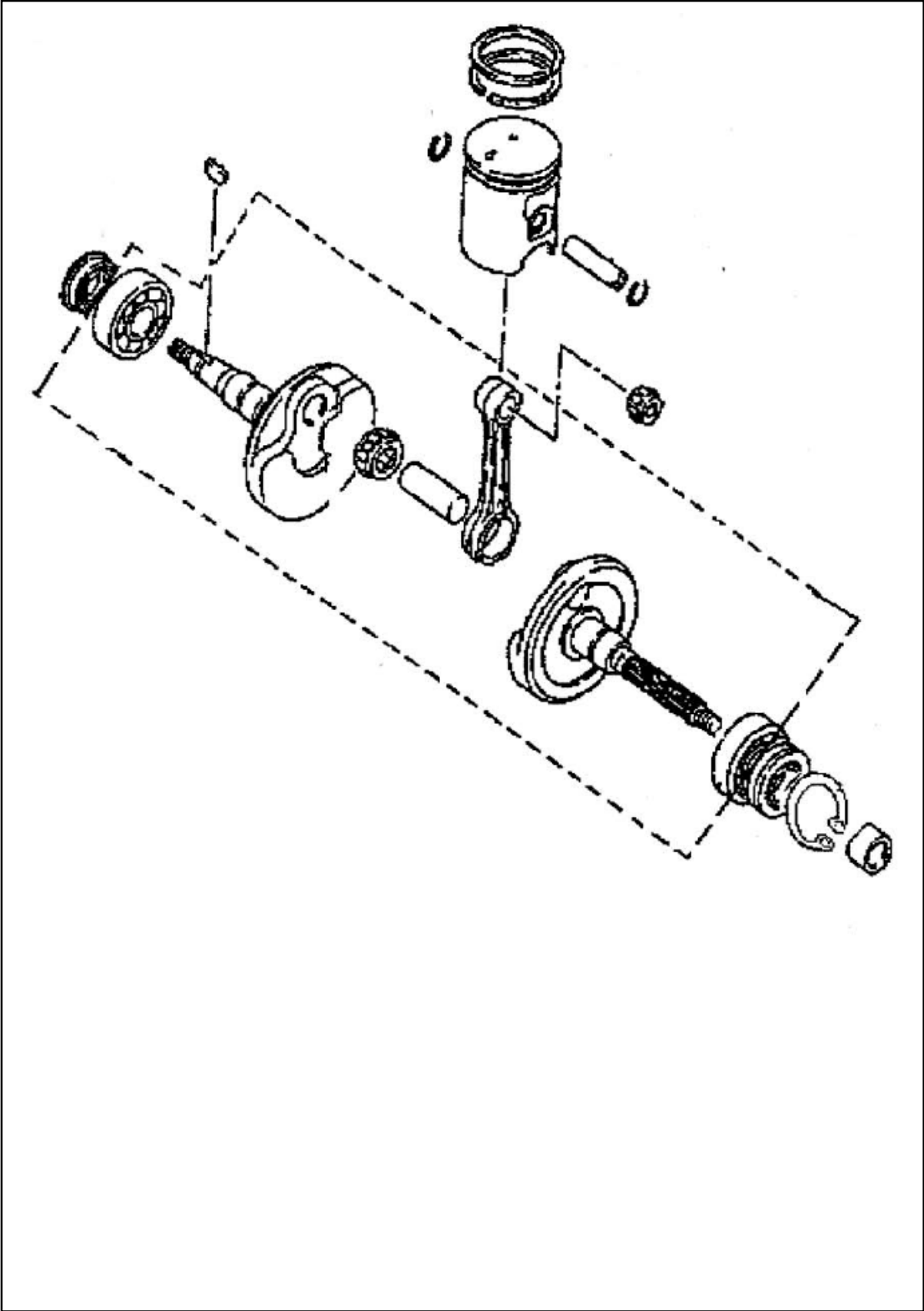

CYLINDER HEAD DISASSEMBLY

Remove the helmet box and the seat.
Remove the spark plug connector.
Remove the muffler.
Remove the carburetor and the air filter body.
Remove the fan covers.



Remove the spark plug.
Loosen the cylinder head nuts.
Remove the cylinder head.

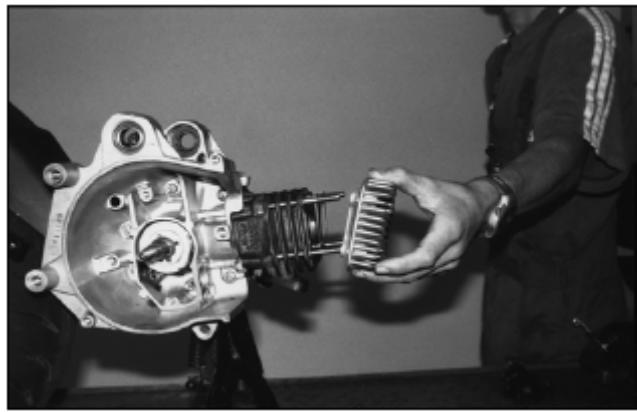

Check the mating surfaces of the cylinder head with a straightedge for warpage.

Limit value: 0.05 mm

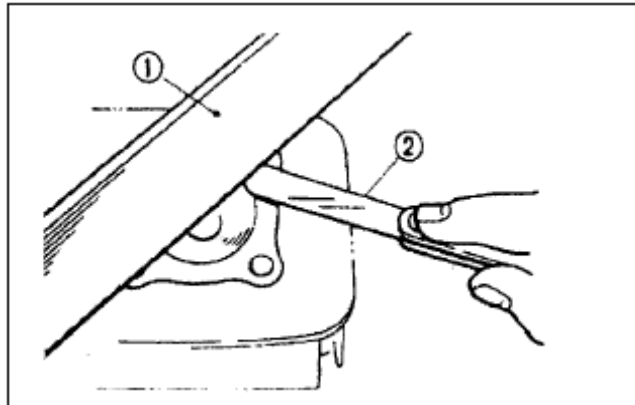

CYLINDER DISASSEMBLY

Remove the cylinder head.
Remove the cylinder.
Remove the cylinder base gasket.

i The gasket surfaces shall be properly cleaned prior to reassembling.

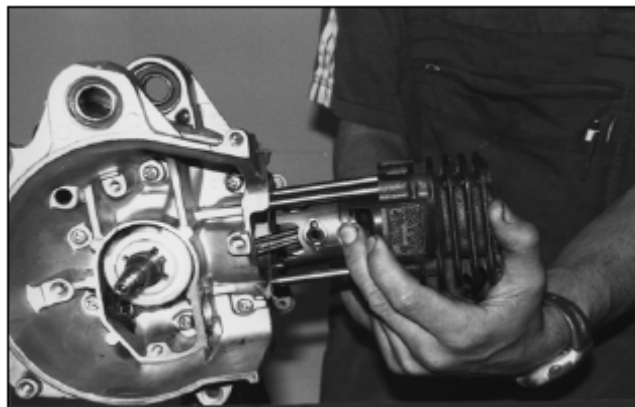

Adjust the piston to the bottom dead center before removing the cylinder.

Carefully remove the cylinder and the base gasket.

Fill the opening of the engine with a rag in order to avoid dirt or foreign material from entering the crankcase.

The inside wall of the cylinder must not show any rougher wear or scores.

The ovality of the tread must be below the given limit value.

Take measurements at three different areas of the tread, each staggered by 90°:

- TDC ring area
- Middle ring area
- BDC ring area

Wear limit: 40.09 mm

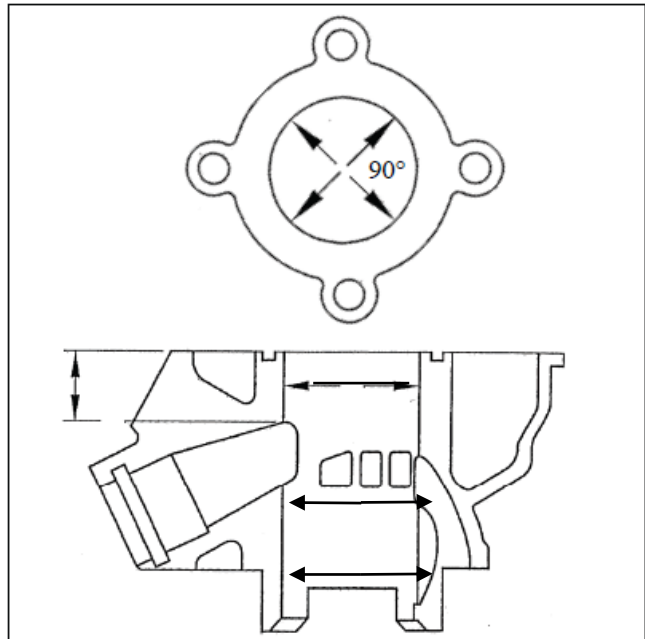

PISTON DISASSEMBLY

Keep the piston on position and remove the circlip of the piston pin with a suitable tool by holding it on one side.

Press out the piston pin towards that side.

Remove the piston and remove the needle bearing from the piston boss.



Fill the opening of the engine with a rag to prevent that the circlips fall into the engine.

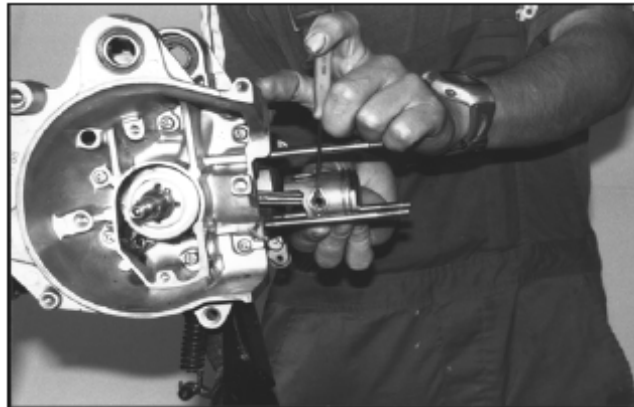

Remove the piston rings.

Carefully clean the piston top, the piston ring grooves and the piston rings from any combustion residues.



Do not strain or break the piston rings!

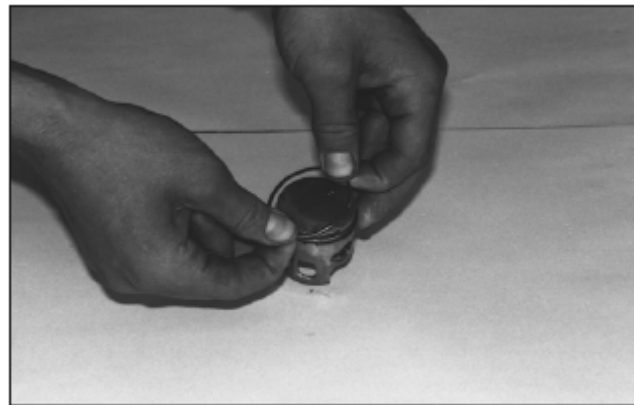

Check the mating surface of the cylinder with a straightedge.

Wear limit: 0.05 mm

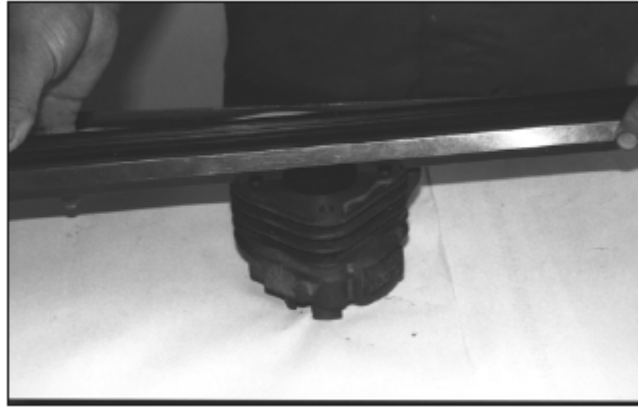

Measure the outside diameter of the piston with a micrometer calliper at a distance of approx. 10 mm, measured from the edge of the piston.

Outside diameter wear limit:

Aragon / *Formula R*: 39.84 mm
Aragon GP: mm

The maximum clearance between piston and cylinder must not exceed the defined limit value. In case of deviations from the limit value both the piston and cylinder have to be replaced.

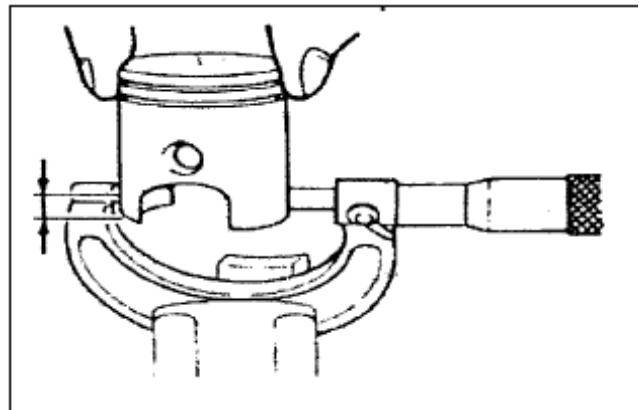

Clearance limit value:

Aragon / *Formula R*: 0.1 mm
Aragon GP: mm

Measure the ovality and the conicity:

Ovality and conicity wear limit:

Aragon / Formula R
Ovality: 0.05 mm
Conicity: 0.05 mm

Aragon GP
Ovality: 0.05 mm
Conicity: 0.05 mm

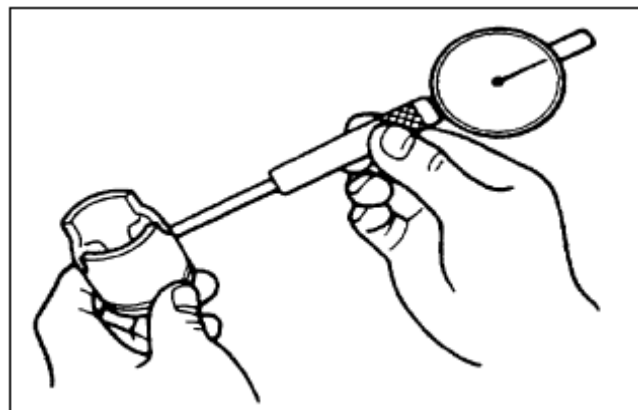

Measure the piston pin boss crosswise.

Wear limit: 10.05 mm

Measure the piston pin crosswise at three spots.

Wear limit: 9.95 mm

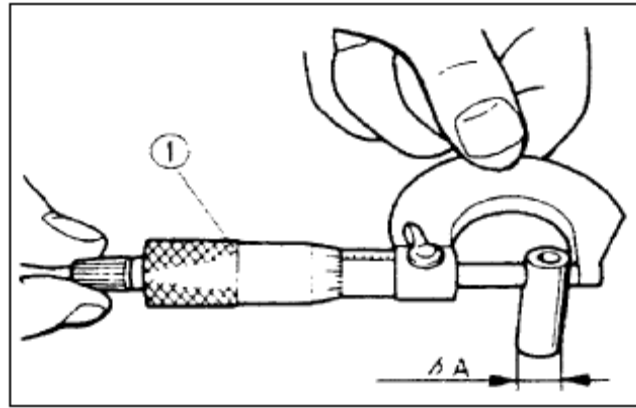

When mounting new piston rings pay attention to whether the bevelled side of the piston rings faces upwards.

Slightly move the piston rings to the left and to the right while watching the position spigots.

Lubricate the piston rings and the ring grooves with a small amount of two-stroke oil.



If piston rings shall be reused, then they have to be checked for wear before they are mounted.

The piston rings have to be pressed in at about 10mm into the slightly oiled cylinder and have to be aligned at a right angle to the tread.

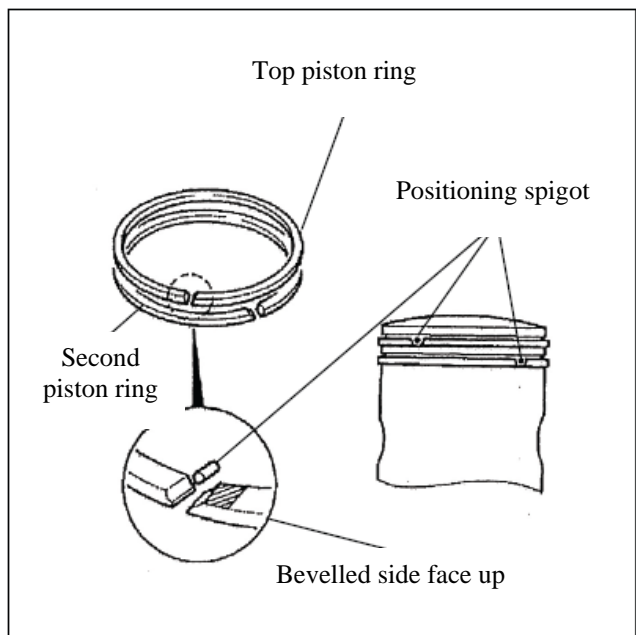

Measure the ring gap of the piston with a feeler gauge in order to ensure that the values are within the specified tolerance.

Wear limit: 0.7 mm

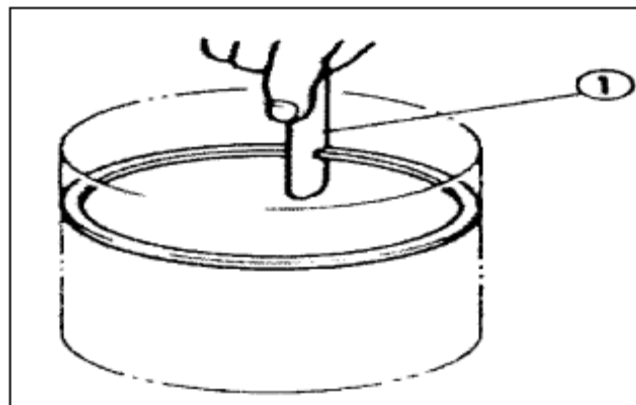

PISTON ASSEMBLY

Put the oiled needle bearing into the connecting rod eye.



Place the piston with its arrow orienting towards the opening. If the arrow is no longer detectable, then the piston ring gaps must always be opposite to the opening.

Slightly press the piston pin into the piston until it meets the circlip. Then install the second circlip.

Prior to placing the piston, the tread of the cylinder and the piston have to be slightly lubricated with two-stroke oil.



The circlips have to be installed in such a way that their fastening hooks are aligned with the direction of movement of the piston.

Check the connecting rod small end.

Wear limit: 14.06 mm

CYLINDER ASSEMBLY

Mount a new cylinder base gasket.

Slightly lubricate the cylinder, the piston, and the piston rings and mount the cylinder.

Torque: 15 Nm

COMPRESSION PRESSURE TESTING



Make sure that the engine has reached its operating temperature and that the throttle valve is fully opened.

Remove the spark plug connector.

Remove the spark plug and connect a compression tester. Turn on the ignition.

Fully open the throttle and start the engine for about 7 – 8 seconds until the display on the tester indicates a stable measuring value.

Compression pressure: 8.5 bar at 600 min⁻¹



All ignition cables shall be grounded prior to pressing the start button to avoid ignition sparks.

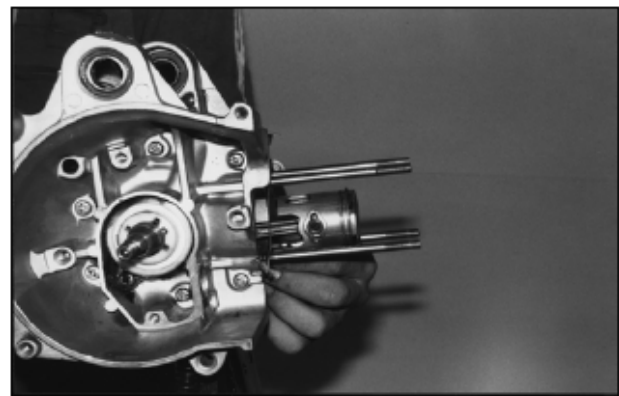
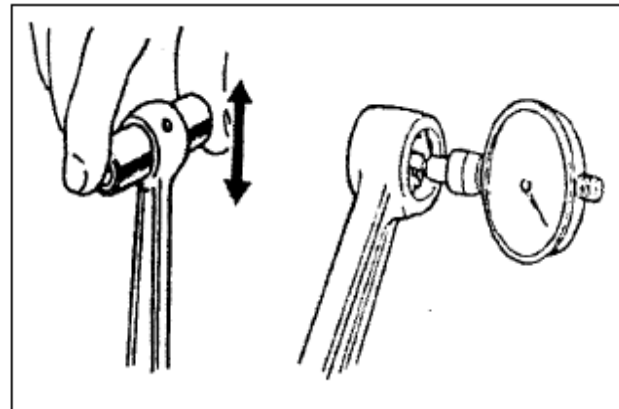
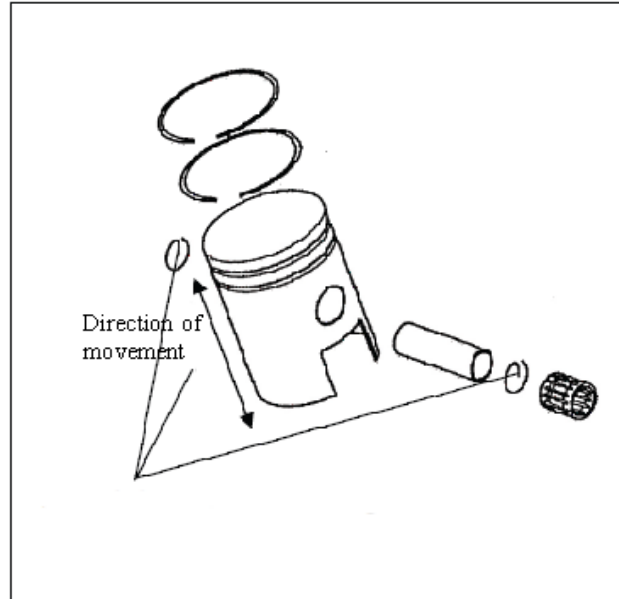

CRANKCASE / CRANKSHAFT

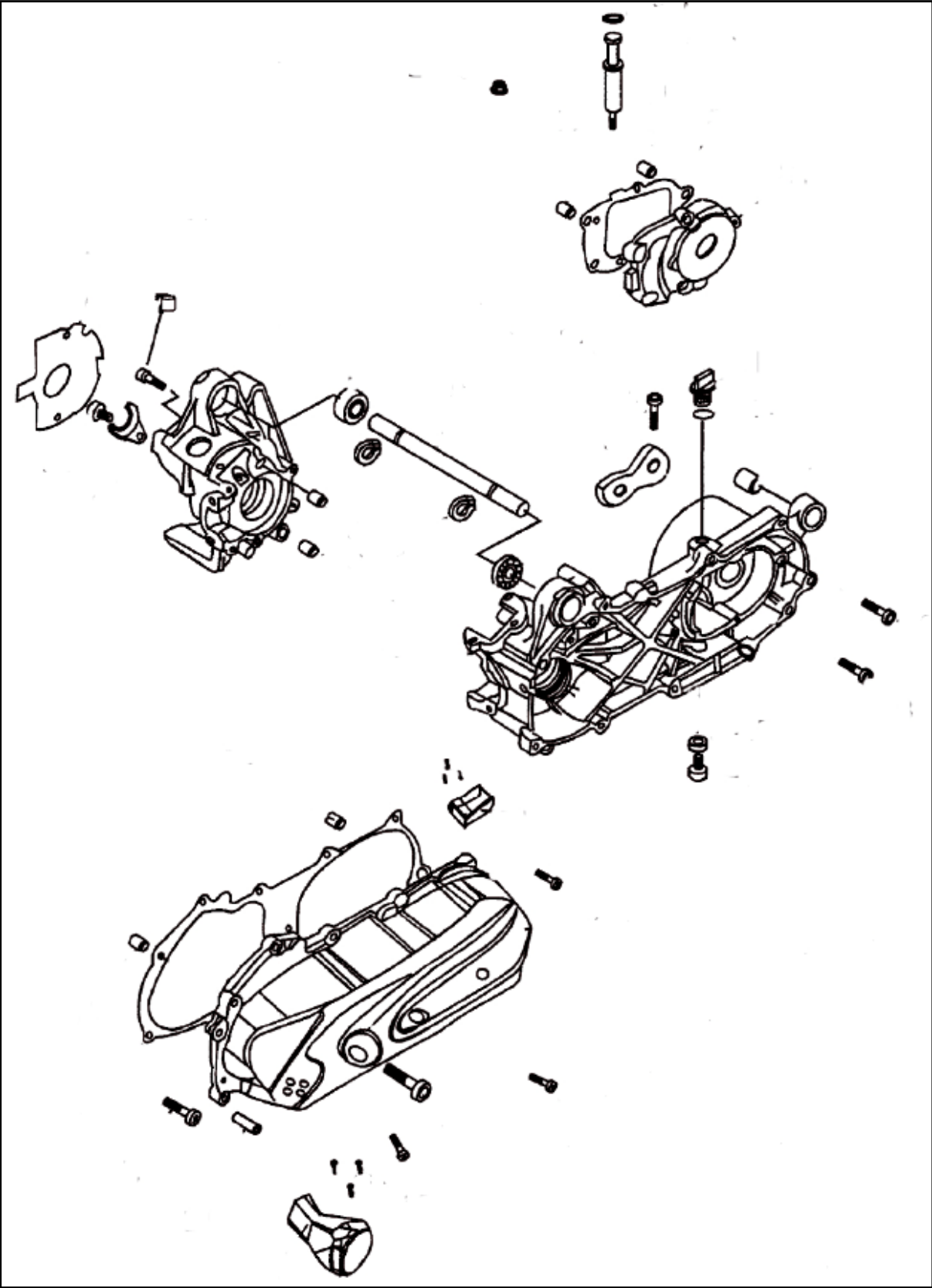

DISMANTLING THE ENGINE CASE

Loosen and remove the engine case bolts. Separate the right crankcase half from the left one with a suitable puller.

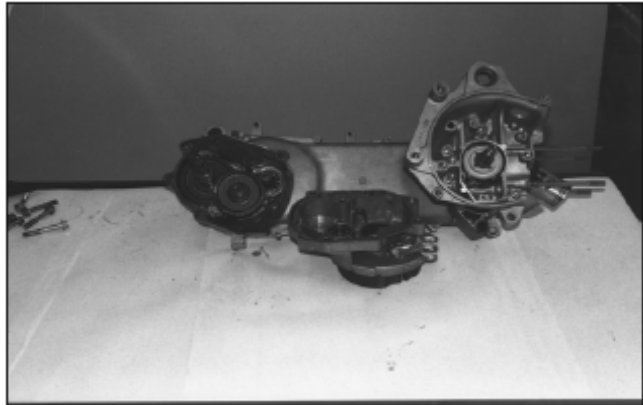

Press out the crankshaft from the left crankcase with the aid of a standard bearing and casing puller.

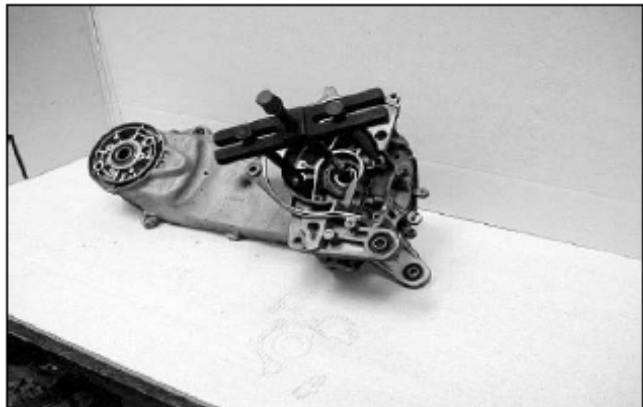

Remove the crankshaft bearings from the crankshaft with a suitable bearing puller.

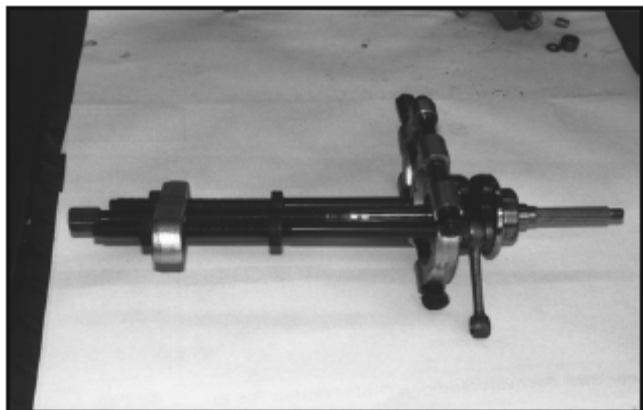

CRANKSHAFT

Check the horizontal and the radial play respectively of the big-end bearing with the aid of a feeler gauge.

The radial play shall be determined by a crossover measurement.

Maximum horizontal play: 0.55 mm

Maximum radial play: 0.05 mm

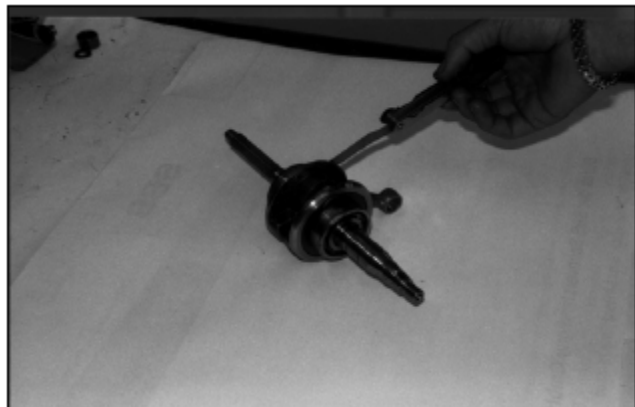

Clamp the crankshaft between two test prods or place it on a vee-block for measuring.

Measure the lateral runout with the aid of two dial gauges.



The actual value is the half of the measured value.

Maximum lateral runout: 0.1 mm

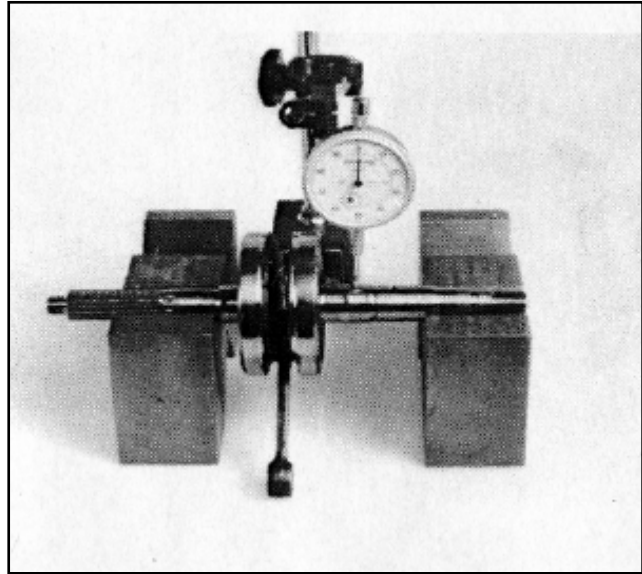

Check the crankshaft bearing clearance. In case of noises or abnormal clearance the bearings shall be replaced.

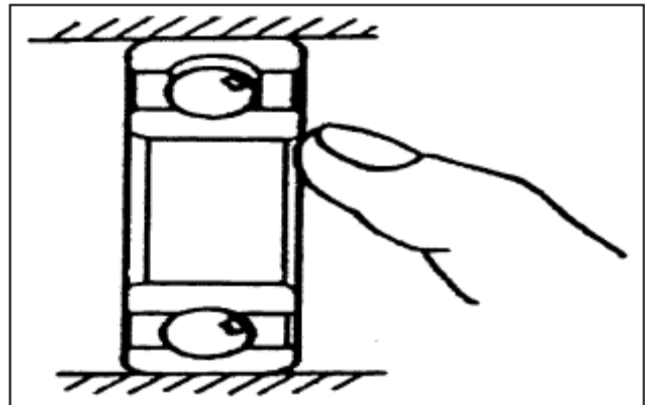

ASSEMBLING THE CRANKCASE

Mount the crankshaft bearing in the left crankcase.



The crankcase shall be heated up to approx. 120°C prior to driving in the bearing. Use temperature indicating chalk.

Special tool: TKF900120

Mount the crankshaft bearing in the right crankcase.



The crankcase shall be heated up to approx. 120°C prior to driving in the bearing. Use temperature indicating chalk.

Special tool: TKF900120



Heat up the crankcase half with the mounted bearing to approx. 120°C.

Mount the crankshaft in the bearing

Clean the mating surfaces of the crankcase halves with a suitable solvent.

Insert the guide sleeves and apply a thin layer of sealing compound to the mating surface of the left crankcase.



Use Loctite® 518 sealing compound only!

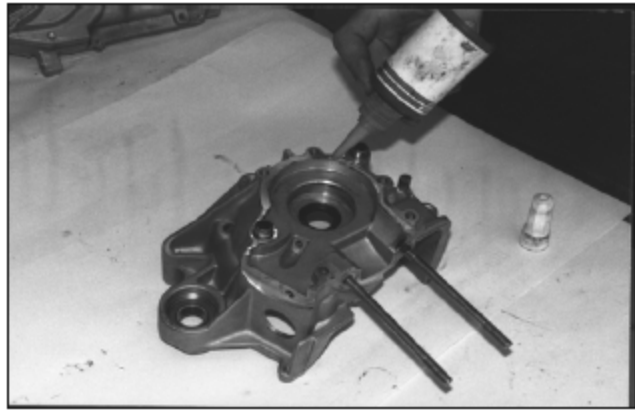

Heated up the right crankcase to approx. 120°C and mount the crankshaft bearing. Use temperature indicating chalk.

Mount the crankshaft in the crankcase.



Mount the left crankshaft seal.



**Grease the shaft seal prior to mounting.
Pay attention not to chock the shaft seal.
The sealing lip must not get damaged!
The shaft seal shall be positioned below the crankcase edge**



Special tool: 000W-10

After the mounting of the crankshaft and check for free movement, the radial crankshaft seals shall be mounted.

Mount the right crankshaft seal.



Grease the shaft seal prior to mounting.
Pay attention not to chock the shaft seal.
The sealing lip must not get damaged!

Special tool: 000W-10

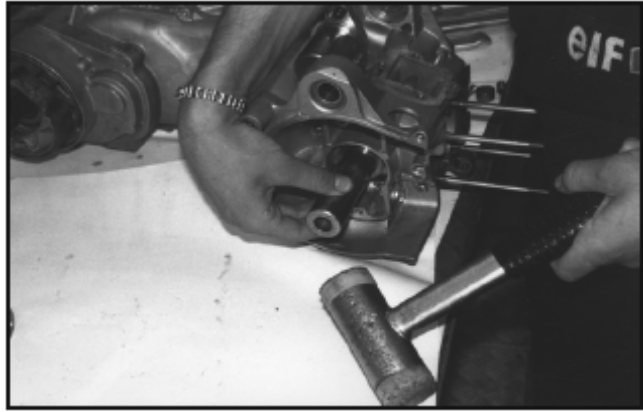

Put together bowth crankcase halves with the crankshaft.

Insert the crankcase mounting bolts and tighten them as per defined torque.

Torque: 10 Nm

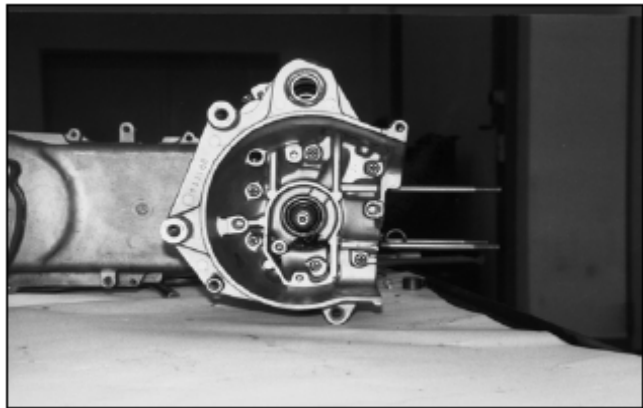

VARIOMATIC TRANSMISSION

SYSTEM OVERVIEW	VT-2
LEFT ENGINE CASE COVER AND BELT-DRIVE REMOVAL	VT-3
V-BELT	VT-4
ROLLER WEIGHT MEASURING	VT-5
ROLLER WEIGHTS CHECK	VT-5
MOVABLE DRIVE FACE	VT-6
CLUTCH SHOE UNIT	VT-7
DISASSEMBLING THE CLUTCH UNIT	VT-7
FAST PULLEY	VT-8
CLUTCH SPRING	VT-8
MOVABLE PULLEY	VT-8
REASSEMBLY	VT-9
TRANSMISSION	VT-9
FINAL DRIVE	VT-9

SYSTEM OVERVIEW

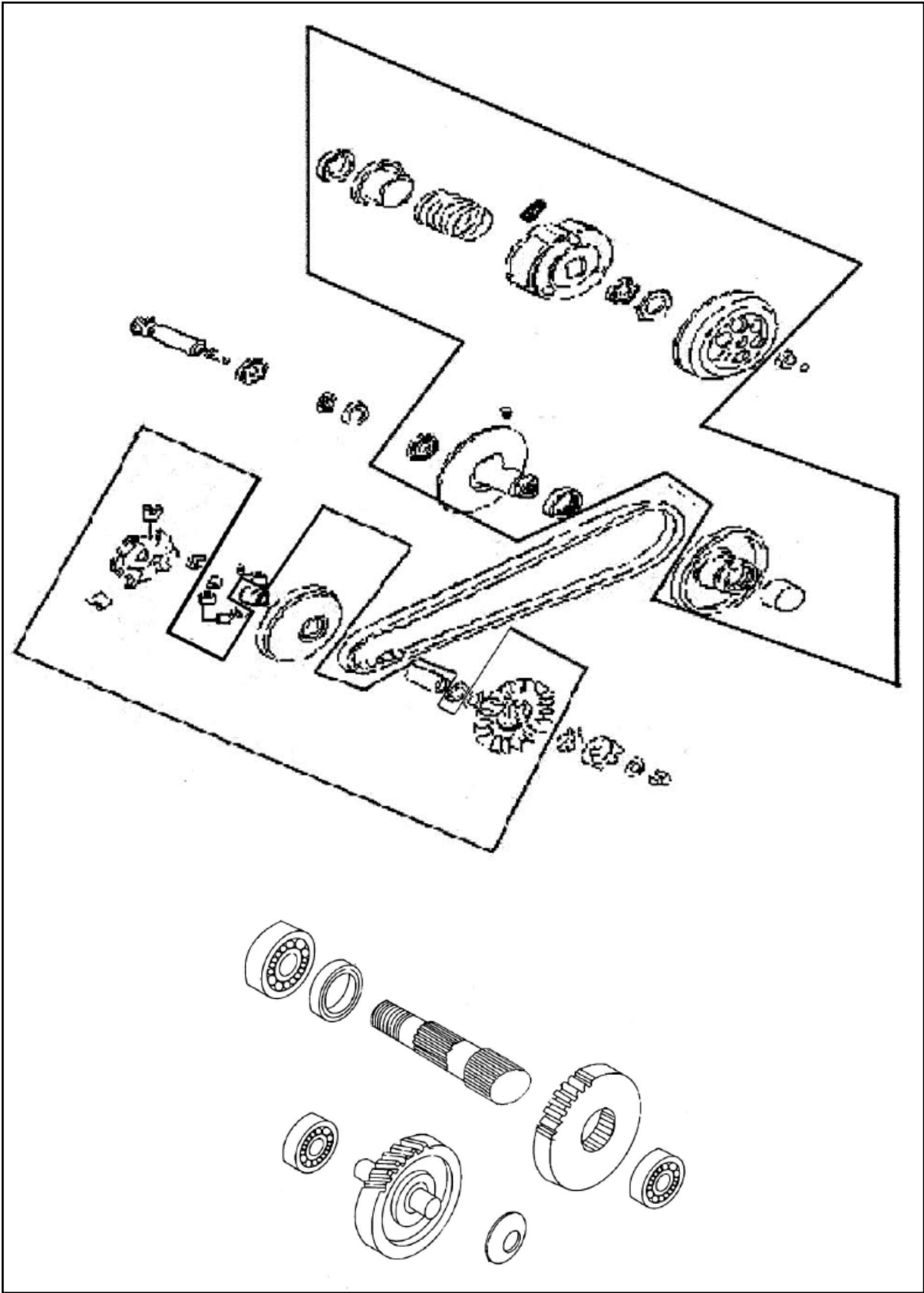

LEFT ENGINE CASE COVER AND BELT-DRIVE REMOVAL

Remove the engine case cover and the bushings.

Loosen the securing nut of the centrifugal clutch and remove the entire clutch together with the V-belt.

Torque: 35 – 40 Nm

Special tool: ACC-ST8362070

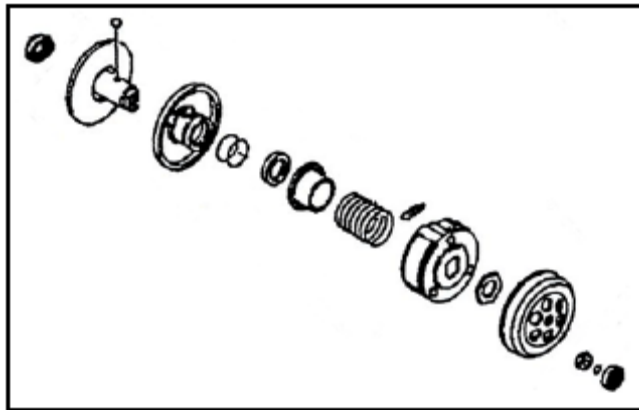

Loosen the securing nut of the continuously variable belt transmission system and remove the variomatic transmission unit.

Torque: 35 – 40 Nm

Special tool: ACC-00005253240

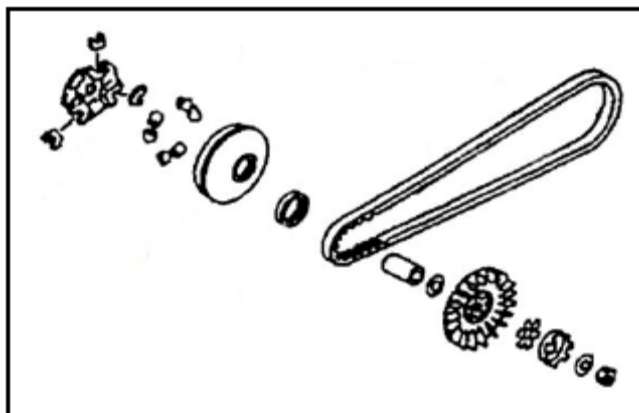

Remove the overrunning clutch and the spacer sleeve.

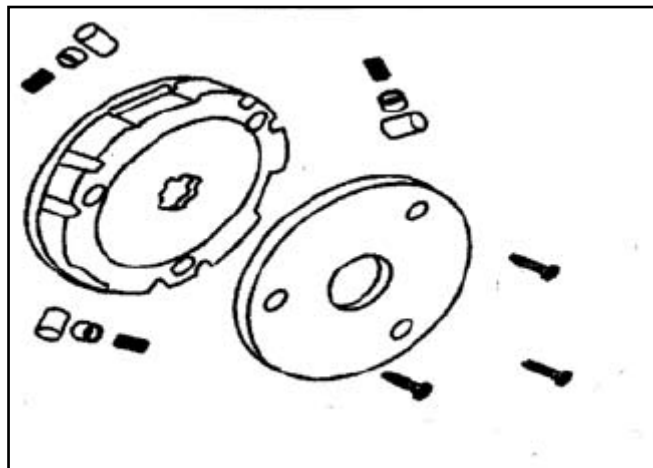

V-BELT

Check the V-belt for break, fissures, aging, and other damages.
 Measure the width of the V-belt upper and lower side.

Upper side wear limit: 16.5 mm
Lower side wear limit: 12 mm

Replace the drive belt if the wear limit is exceeded.

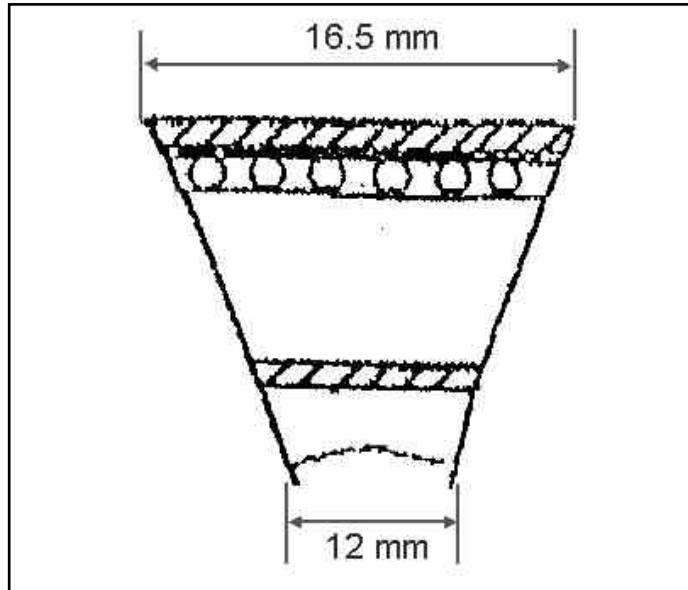

If the lower side width is less than the defined wear limit the angle of the V-belt shape is changed.

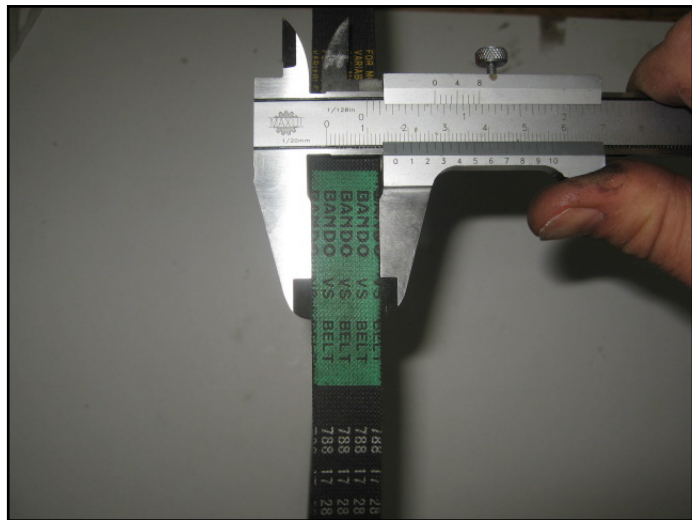

Note that the proper functioning of the belt transmission is not ensured if the belt width is less than the defined wear limit.



ROLLER WEIGHTS MEASURING

Measure the diameter of the roller weights.

Standard value: 15 mm



Measure the height of the roller weight.

Standard value: 12 mm

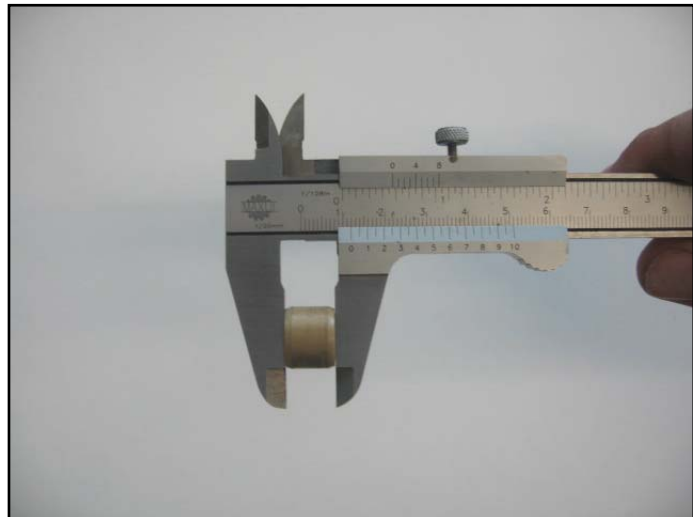

ROLLER WEIGHTS CHECK

Check the roller weights for wear and damage. Replace damaged or excessively worn roller weights.

Check the roller weights for roundness. If roller weights are flattened too much they shall be replaced on the technician's own discretion.

i Excessively worn, damaged, or flattened roller weights have negative effect on the proper functioning of the continuously variable belt transmission. The torque / power ratio is no longer given particularly upon the vehicle acceleration or during downhill driving.

MOVABLE DRIVE FACE

Measure the diameter of the sintered metal sliding bearing.

Wear limit: 21.10 mm



Check the guide sleeve for scuffing, cracks etc. and replace it if necessary.

Measure the diameter of the guide sleeve.

Wear limit: 20.90 mm



Measure the inside diameter of the clutch bell housing.

Wear limit: 112.4 mm



Note: Any blue tint of the clutch bell housing has no negative effect on the functioning of the clutch friction.

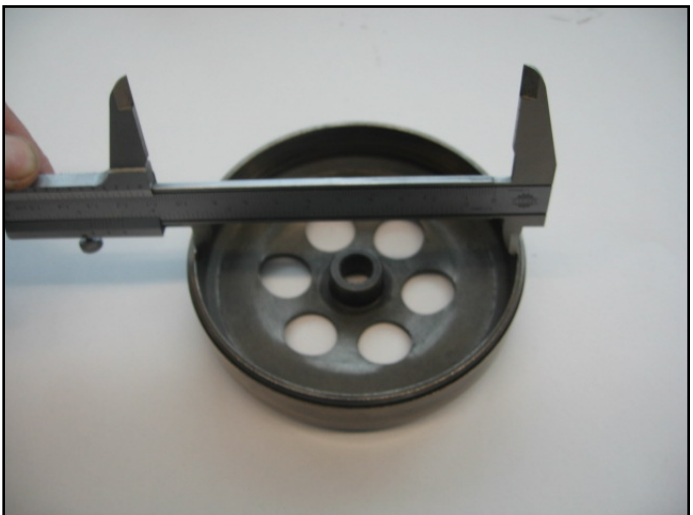

CLUTCH SHOE UNIT.

Measure the breadth of the clutch lining.

Wear limit: 1.5 mm

Check whether the linings adhere to the clutch and make sure they do not come loose.

Check the individual clutch shoes for free movement. They shall not get jammed or stuck.

Check whether the rubber stop pins are available.

Check the stop pins for wear, crackings or aging.



DISASSEMBLING THE CLUTCH UNIT



When disassembling the clutch unit make sure that all components are adequately cleaned. This will ensure that they can be properly measured.

Fix the clutch unit with a specially designed tool.

Loosen the 38 mm clutch nut.

Release the clutch spring and dismantle the clutch.

Special tool: ACC-00005253240



FAST PULLEY

Check the ball bearing and the needle bearing of the fast pulley for proper functioning.

Replace the bearings if they do not run smoothly.

Check the diameter of the fast pulley.

Limit value: 32.90 mm

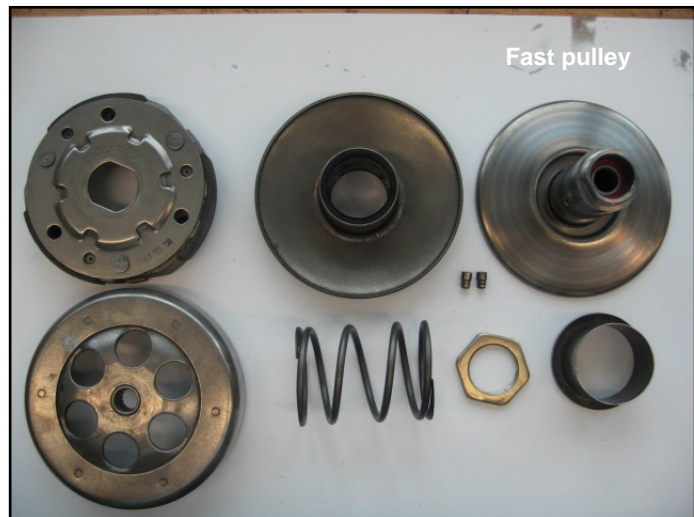

CLUTCH SPRING

Measure the free length of the clutch spring.

	Clutch spring length	
	67 mm	103 mm
JR	25 km/h	30 / 45 km/h
Aragon GP	25 / 30 km/h	45 km/h
Formula R	25 / 30 km/h	45 km/h

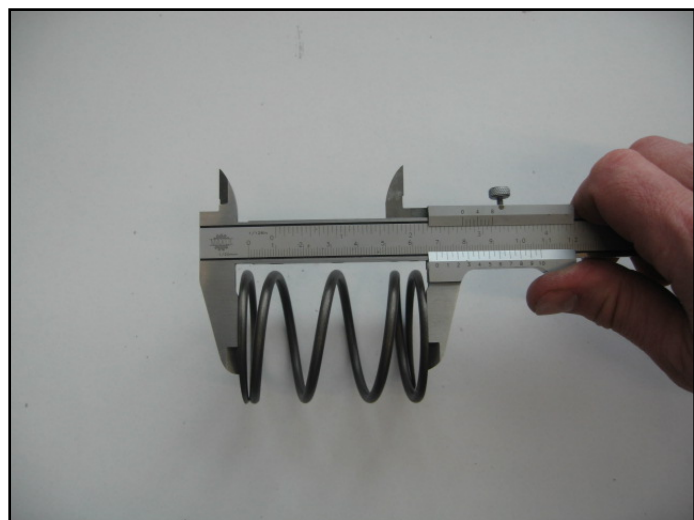

MOVABLE PULLEY

Measure the inside and the outside diameter of the movable pulley.

Check the O-rings and the sealing rings for damage and wear.

Wear limit: 33.10 mm

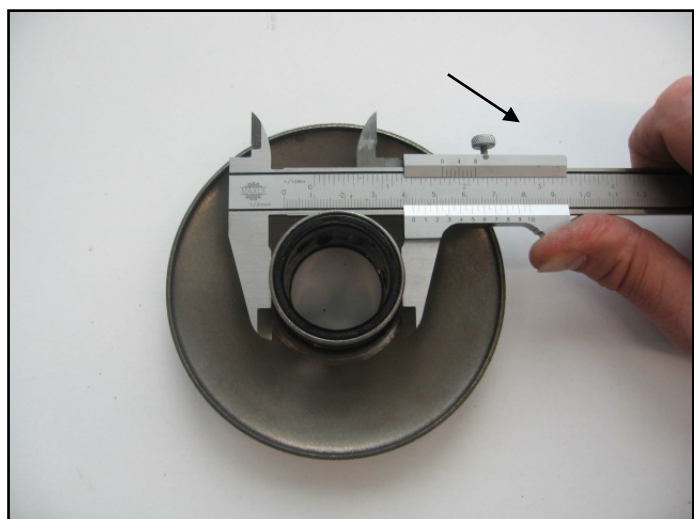

Check the lock pins and the guide and the guide way in the movable pulley for damage or scoring.

REASSEMBLY

Assembly the clutch in reverse order.



Grease all movable parts upon the reassembly of the clutch in order to ensure the free movement of the clutch component parts. Check the functioning of the clutch (i.e. its free movement) subsequent to the reassembly.



TRANSMISSION

Remove the transmission output shaft and the intermediate shaft.



When removing the intermediate shaft, pay attention to the thrust washer. It must not get lost upon the removal of the intermediate shaft.

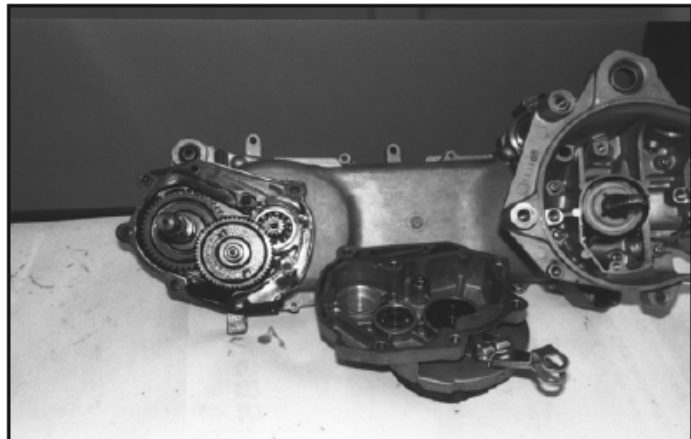

FINAL DRIVE

Check all gears and shafts for wear and damage.

Oil filling capacity:

**100 ml SAE 80/90 when refilling
120 ml after disassembly and reassembly**

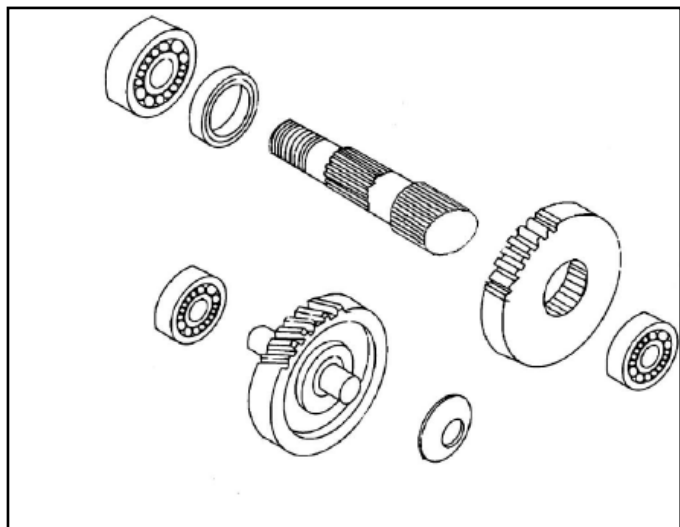

ELECTRICAL SYSTEM

GENERATOR REMOVAL	ES-2
GENERATOR INSTALLATION	ES-3
STARTER BATTERY CHECK	ES-4
STARTER BATTERY CHARGING	ES-4
LIGHT / CHARGING COIL	ES-4
RESISTANCE CHECK (DUMMY CONSUMERS)	ES-5
IGNITION COIL	ES-5
MAGNETO IGNITION	ES-6
PULSE GENERATOR	ES-6
IGNITION TIMING ADJUSTMENT	ES-6
STARTING MOTOR RELAY	ES-7
FUEL LEVEL SENSOR	ES-8
FUEL LEVEL INDICATOR	ES-8
OIL LEVEL SENSOR	ES-8
HEADLIGHT DIMMER	ES-9
STARTER BUTTON	ES-9
LIGHT CONTROL	ES-9
TURN SIGNAL SWITCH	ES-9
HORN SWITCH	ES-9
IGNITION AND STARTER SWITCH	ES-9
WIRING DIAGRAMS	ES-10

GENERATOR REMOVAL

Remove the seat and the helmet box.
Remove the blower hood.



Loosen the impeller screws and remove the impeller.



Immobilize the flywheel with a suitable tool and loosen the lock nut with a socket wrench.

Torque: 35 Nm

Special tool: ACC-00G05300011

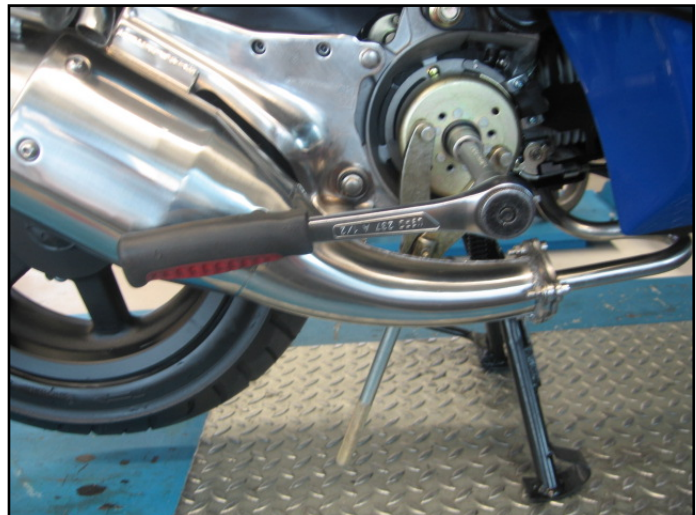

Remove the flywheel with a suitable puller.

Special tool: AB-09



Disconnect the plug-in connection from the generator.

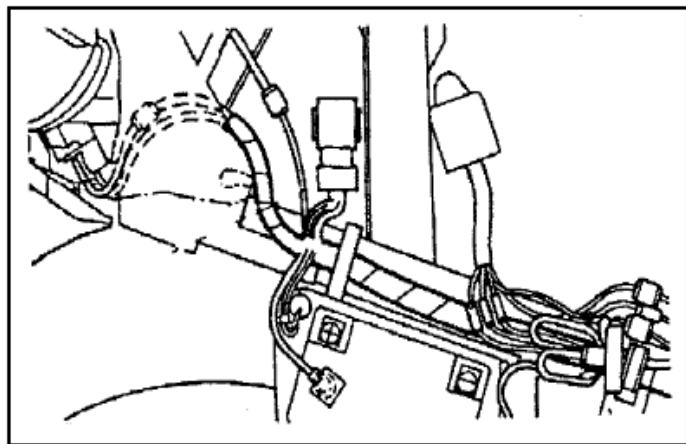

Loosen the securing bolts of the stator assembly and remove the stator.

GENERATOR INSTALLATION

The generator shall be installed in reverse order.

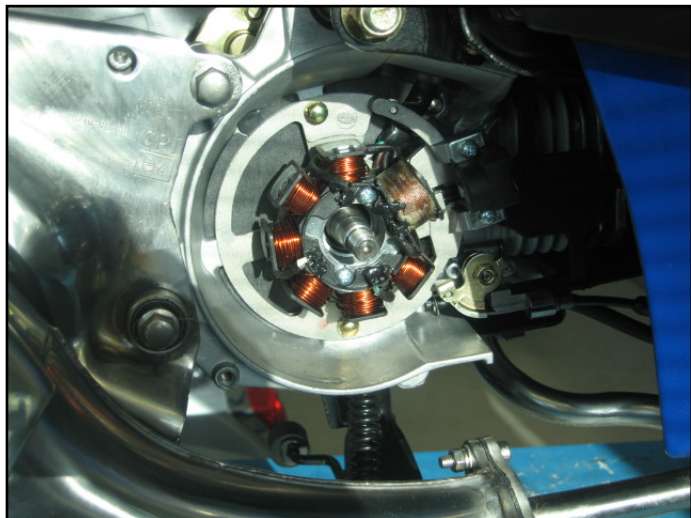

STARTER BATTERY CHECK

Measure the voltage of the starter battery.

Fully charged: 13.0 ~ 13.2 V

Discharged: 11 V

Measure the charging voltage.

14 ± 0.5 V at 5000 rpm

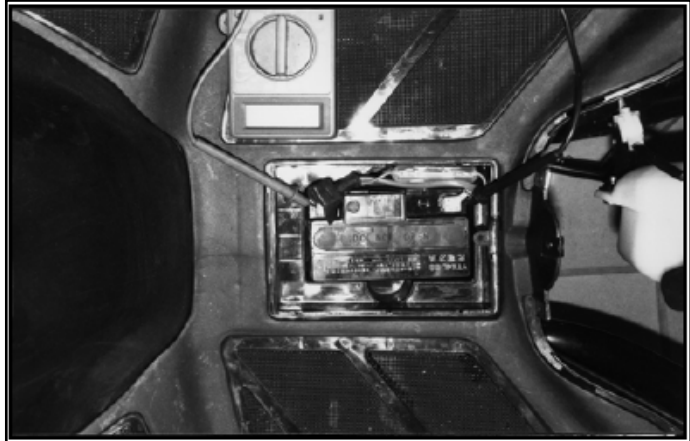

STARTER BATTERY CHARGING



The CPI JR comes with a maintenance-free starter battery. Use battery chargers that are suited for those battery types (e.g. Optimate / Tec Mate® International S.A. B-3300 Tienen, Belgium). The use of non-suited chargers may cause damages to the starter battery.

Charging current: 0.4 A

Charging time: 5 ± 0.5 hours

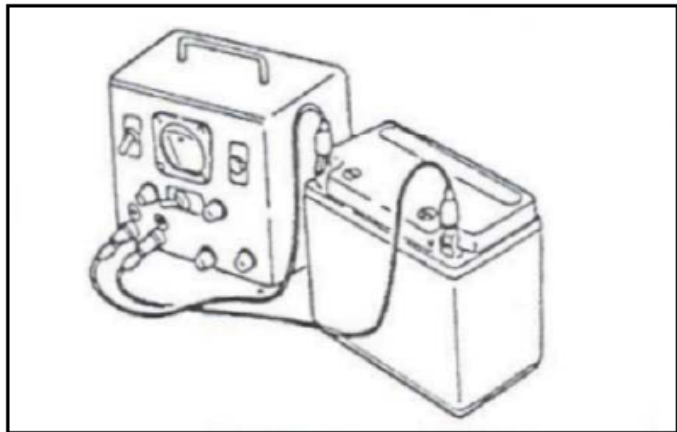

LIGHT/ CHARGING COIL

Light coil: Measure the resistance between the green/red and black cables.

Desired value: $0.8 \pm 0.4 \Omega$ at 20°C ambient temperature

Charging coil: Measure the resistance between the white and black cables.

Desired value: $0.8 \pm 0.4 \Omega$ at 20°C ambient temperature

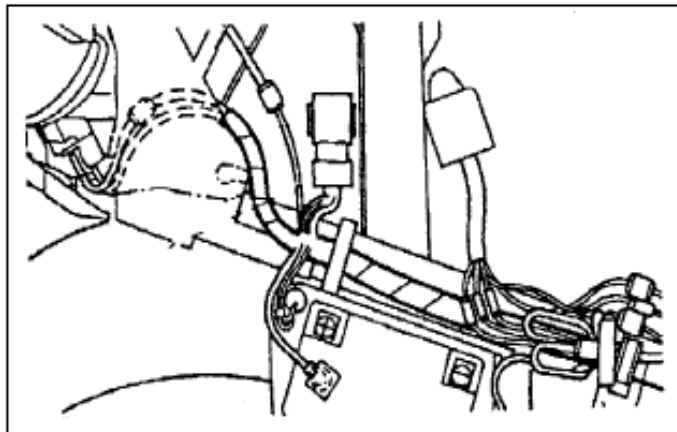

RESISTANCE CHECK (DUMMY CONSUMERS)

Measure the resistance against ground.

Desired value: $6.4 \pm 0.2 \Omega$ at 20°C
ambient temperature



IGNITION COIL

Measure the primary coil winding with an ohmmeter.

Desired value: $0.4 \sim 0.6 \Omega$ at 20°C
ambient temperature

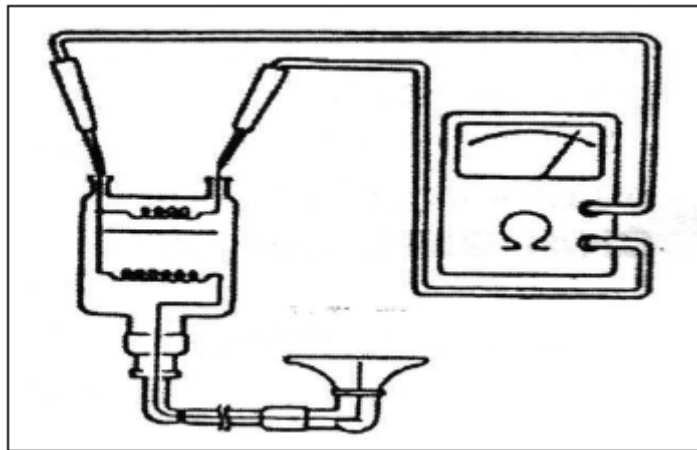

Measure the secondary coil winding with an ohmmeter.

Desired value at 20°C ambient
temperature:

With spark-plug connector: 10 ± 1
 $\text{k}\Omega$

Without plug connector: $3 \pm 0.5 \text{ k}\Omega$

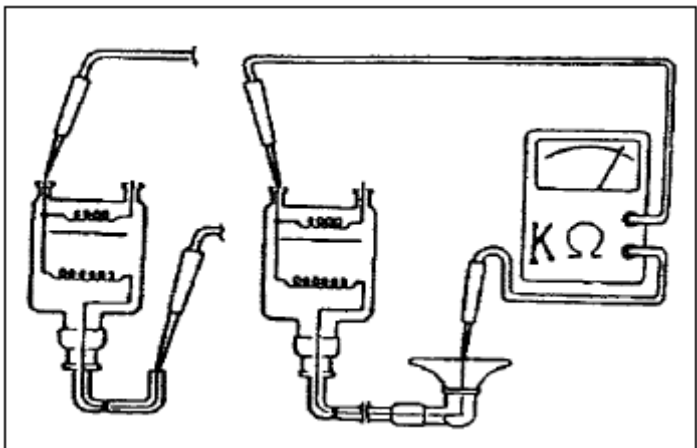

MAGNETO IGNITION

Checking the exciting coil:

Disconnect the plug connection of the black/red cable and measure the black/red cable against ground with the aid of an ohmmeter.

Desired value: $900 \pm 100 \text{ k}\Omega$ at 20°C

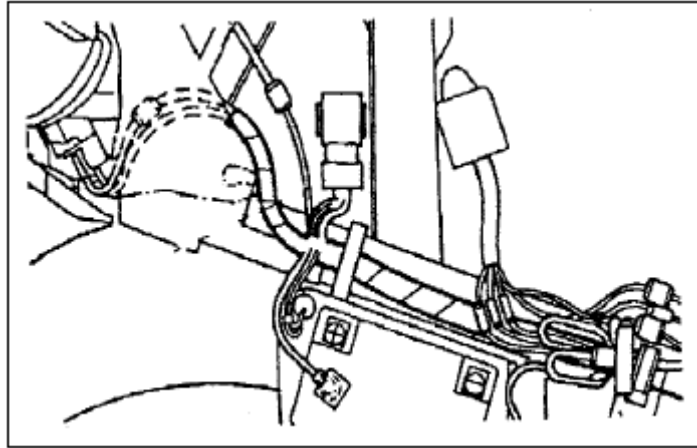

PULSE GENERATOR

Disconnect the plug connections of the blue/white - green/white cables and measure the cable against ground with an ohmmeter.

Desired value: $340 \pm 50 \Omega$ at 20°C

IGNITION TIMING ADJUSTMENT



The ignition point shall be adjusted when the engine has reached its operating temperature. Use a stroboscopic lamp for the ignition point checking .

Procedure:

Mark the engine case with an ignition marking.

Unplug the spark plug connector.

Screw off the spark plug.

Insert tool in spark plug hole until it meets the piston.

Turn the magnet wheel to the right until the piston reaches its top dead center (TDC).

Mark the magnet wheel with a marking opposite to the engine case marking.

Turn the magnet wheel to the left until the piston reaches the TDC again.

Measure the distance between the two markings.

The overlap point is the actual TDC.

Connect the stroboscopic lamp and start the engine.

Turn the setting wheel of the of the stroboscopic lamp until the TDC marking on the magnet wheel is congruent to the TDC marking on the engine case.

Desired value: 17° (1800 rpm)

STARTING MOTOR

Connect a fully charged starter battery and measure the engine capacitance.

Current consumption: approx. 20A

Special tool: AB-239917

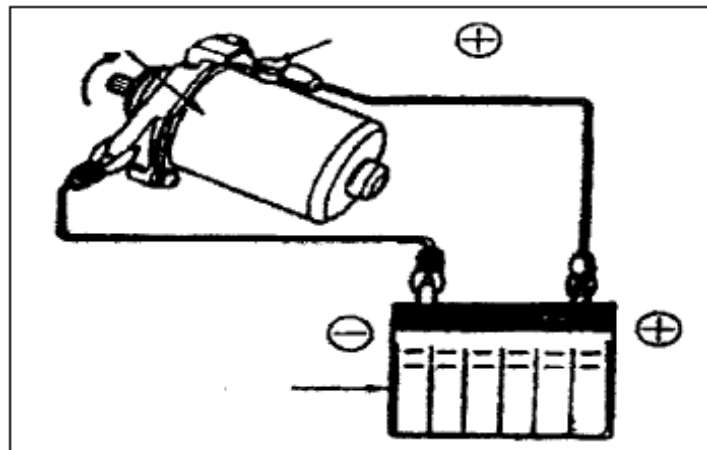

STARTING MOTOR RELAY

Connect the starting motor relay 30+ contact and the ground contact to a 12V current source [(+) green/red; \equiv yellow] and measure the continuity between the two screw terminals.

Continuity -> okay

No continuity -> not okay

Measure the resistance:

Green/red:

Yellow: $3.8 \pm 0.5 \Omega$



FUEL LEVEL SENSOR

Measure the resistance of the fuel level indicator.

- Float up:** 5.5 Ω ~ 7 Ω
- Float down:** 84 Ω ~ 86.5 Ω

FUEL LEVEL INDICATOR

Turn off the ignition and remove the fuel level sensor from the fuel tank.

Move the float up and check whether the fuel level indicator also moves from “E” to “F”.

Move the float down and check whether the indicator moves from “F” to “E” as well.

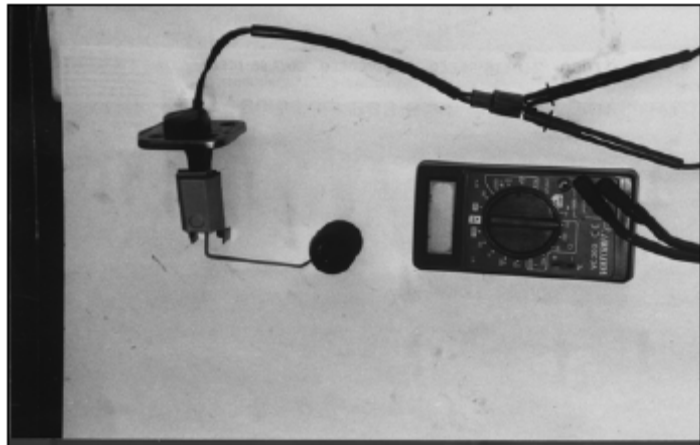

OIL LEVEL SENSOR

Remove the seat and the helmet box. Disconnect the plug connection of the oil level sensor. Remove the the sensor from the oil reservoir.

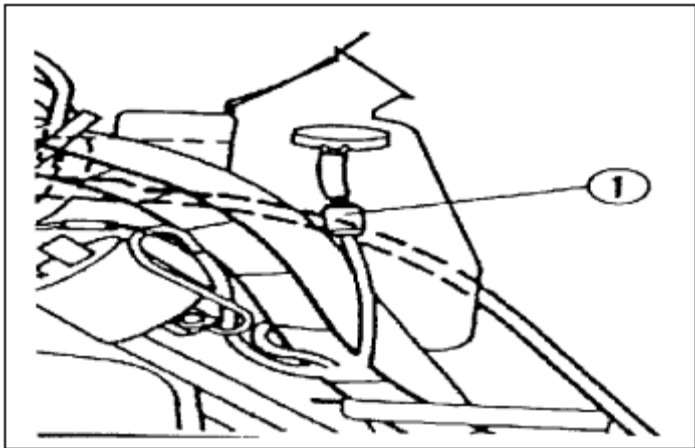

Measure the continuity of the red/white and blue cables.

Float Position \	OK	NOK
Up	X	O
Down	O	X

O = continuity
X = no continuity

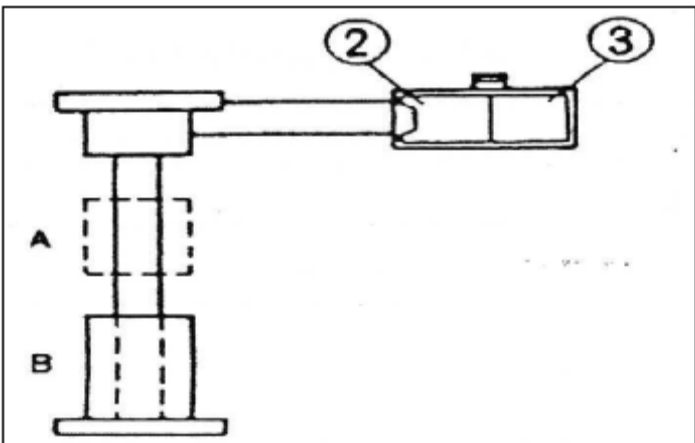

HEADLIGHT DIMMER

Color Position	Light blue	Yellow w Red	Dark blue
High beam		● ————— ●	
Low beam	● ————— ●		

STARTER BUTTON

Color Position	Green/ Yellow/Brown	Black
OFF		
ON	● ————— ●	

i Note that the plug connections shall be disconnected prior to measuring.

LIGHT CONTROL

Color Position	Yellow / Red	Green / Red	Brown / White	Yellow	Pink
Off		● ————— ●			●
Parking light		● ————— ●	●	●	
Running light	●	●		●	

TURN SIGNAL SWITCH

Color Position	Green/ White	Orange	Green/ Black
Left		● ————— ●	
Neutral			
Right	● ————— ●		

HORN SWITCH

Color Position	Brown	Black
On	● ————— ●	
Off		

IGNITION AND STARTER SWITCH

Color Position	Red	Dark green	Black	Red / White	Gray
Off		● ————— ●			
On	● ————— ●			●	
* (Check)	●				●

WIRING DIAGRAMS

Aragon GP

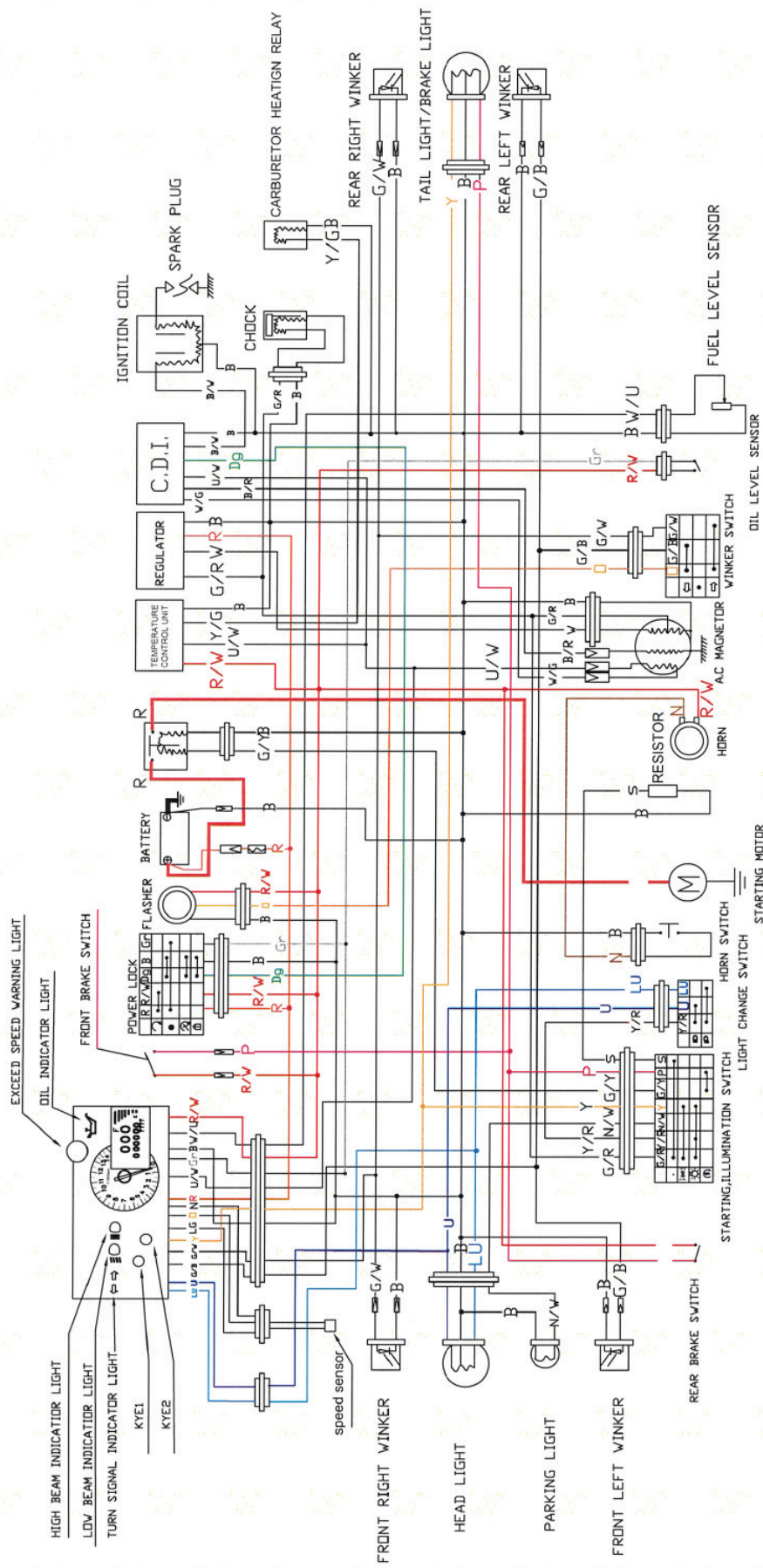

CODE	B	R	W	U	G	O	Y	P	N	LU	Dg	Gr	S
LINE COLOR	BLACK	RED	WHITE	BLUE	GREEN	ORANGE	YELLOW	PURPLE	BROWN	LIGHT BLUE	DARK GREEN	GREY	PINK

Aragon

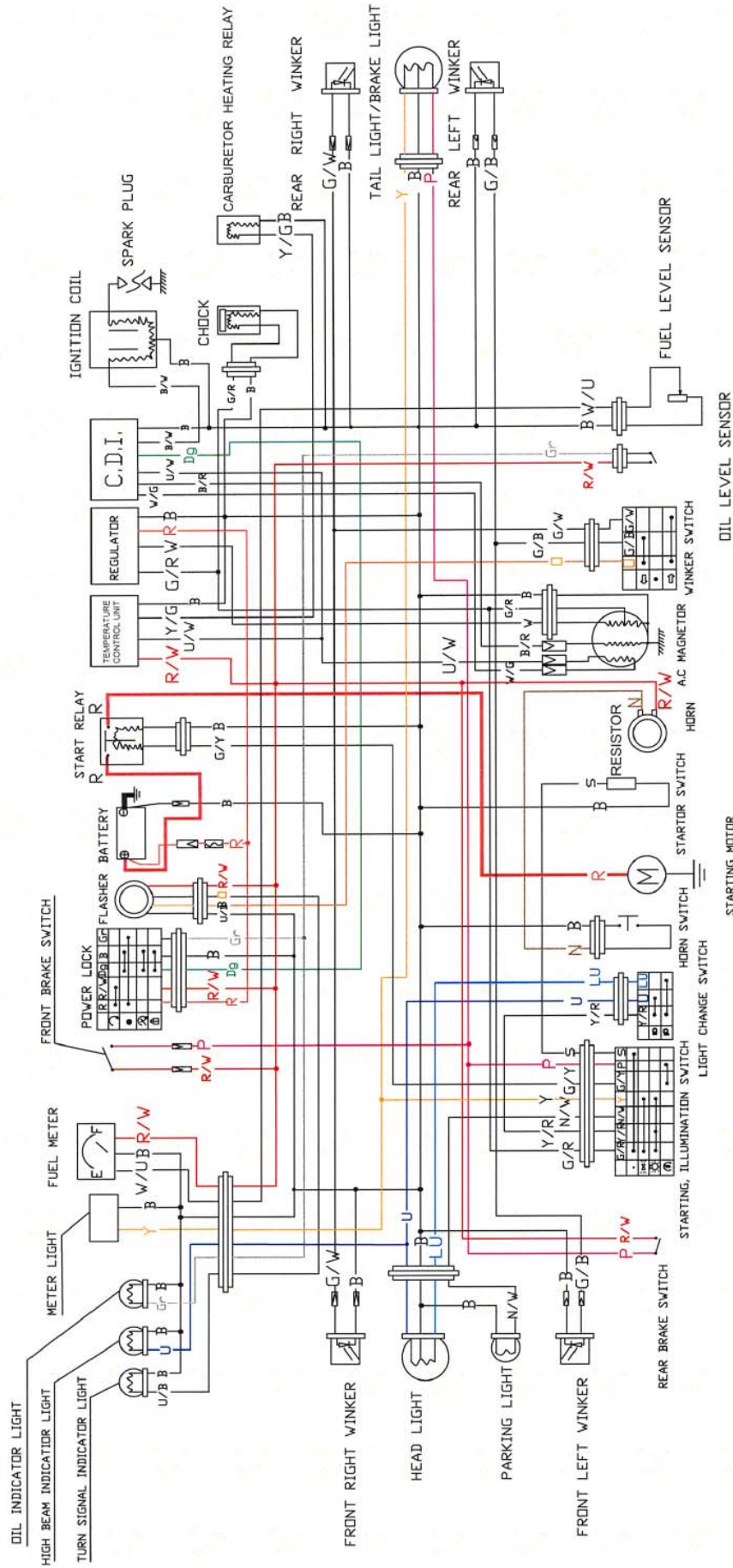

CODE	B	R	W	U	G	Q	Y	P	N	LU	Dg	Gr	S
LINE COLOR	BLACK	RED	WHITE	BLUE	GREEN	ORANGE	YELLOW	PURPLE	BROWN	LIGHT BLUE	DARK GREEN	GREY	PINK

Formula R

